

PHILIPS

AC2936, AC2939

Original instruction by Philips



EN	User manual	1	IT	Manuale utente	67
DA	Brugervejledning	12	NL	Gebruiksaanwijzing	78
DE	Benutzerhandbuch	23	NO	Brukerhåndbok	88
ES	Manual del usuario	34	PT	Manual do utilizador	98
FI	Käyttöopas	45	SV	Användarhandbok	109
FR	Mode d'emploi	56			



1

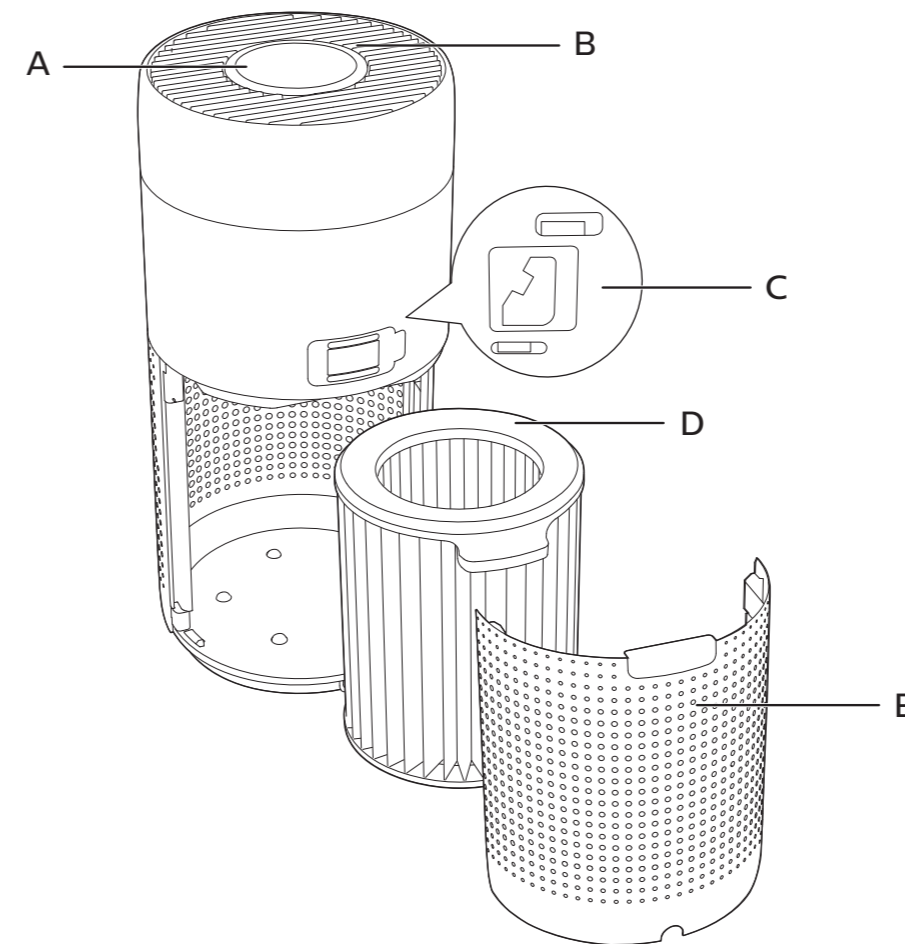

2

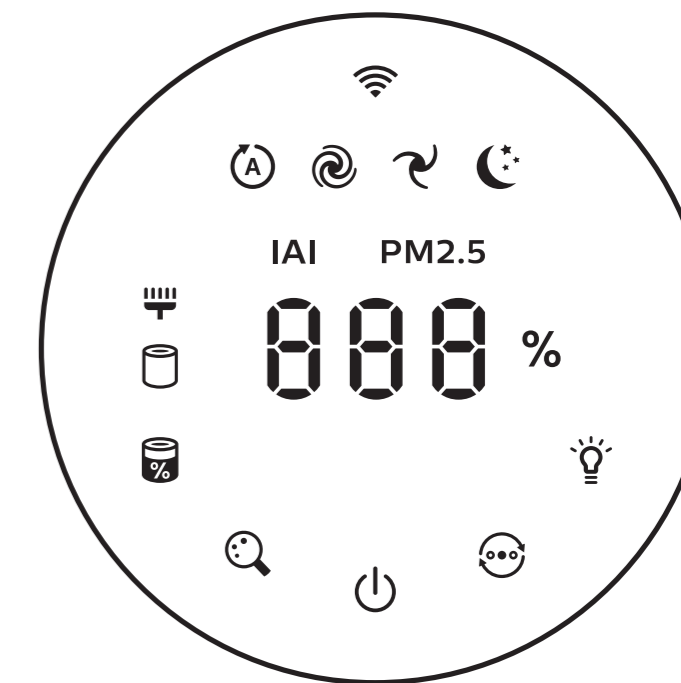

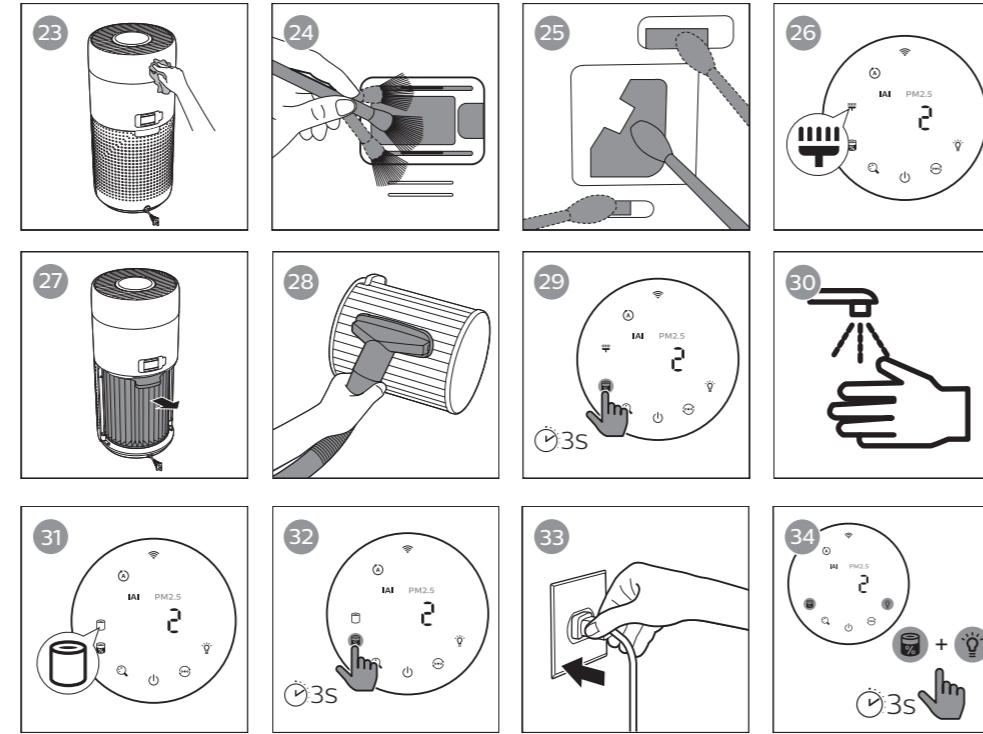
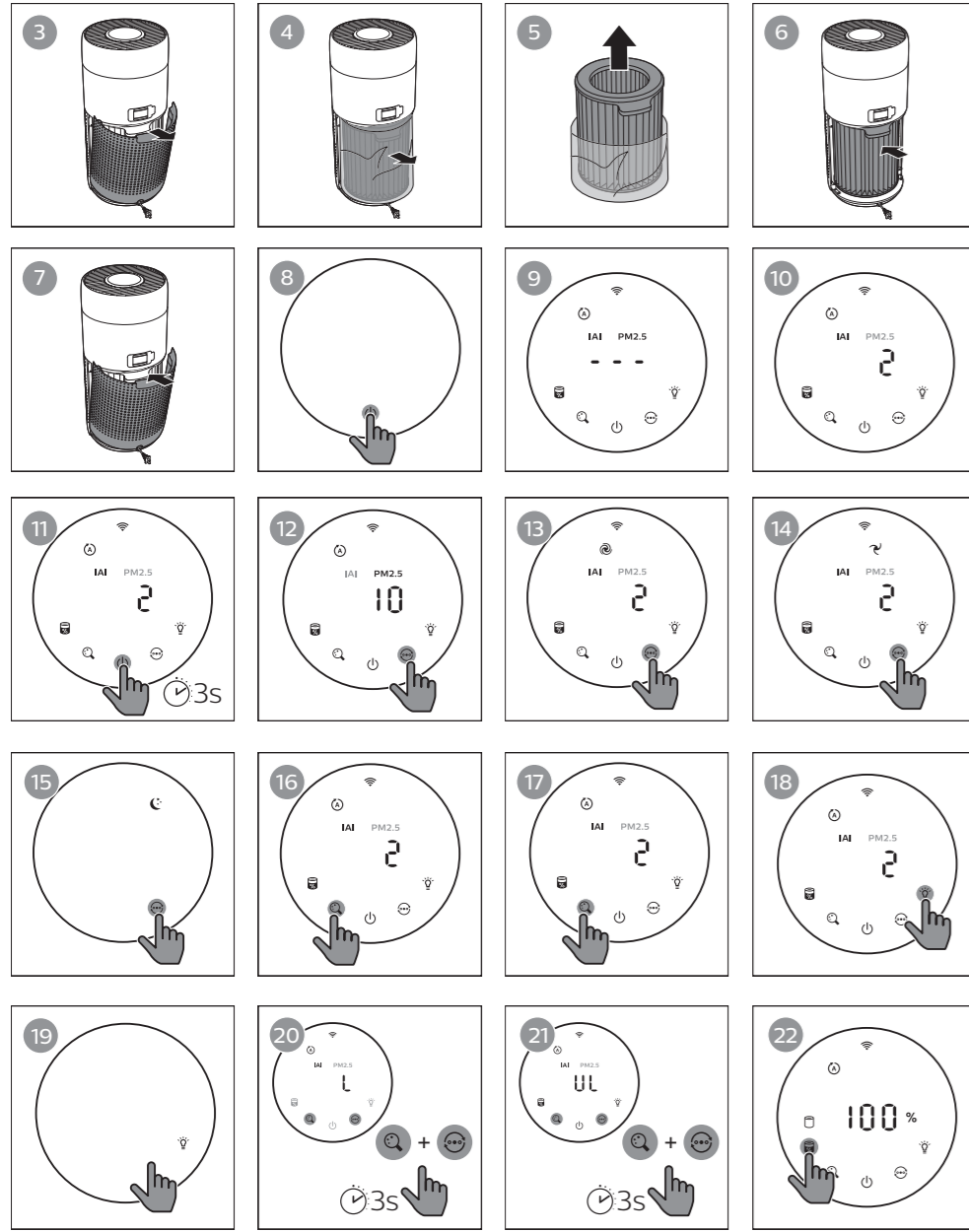

Contents

1	Your air purifier	2
	Product overview (Fig ①)	2
	Controls overview (Fig ②)	2
2	Getting started	3
	Installing the filter	3
	Wi-Fi indicator	3
	Wi-Fi connection	3
3	Using the air purifier	4
	Air quality light	4
	Turning On and Off	5
	Changing the mode setting	5
	Switching the display indicator	5
	Using the light on/off function	5
	Setting the child lock	6
	Checking the filter status	6
4	Cleaning and maintenance	6
	Cleaning the body of the air purifier	6
	Cleaning the particle sensor	6
	Cleaning the surface of the filter	7
	Replacing the filter	7
	Filter reset	7
5	Storage	8
6	Troubleshooting	8

1 Your air purifier









Congratulations on your purchase of air cleaner AC2936/AC2939.

To fully benefit from the support that Philips offers, register your product at www.philips.com/welcome.

Product overview (Fig ①)

- A Control panel
- B Air outlet
- C Particle sensor
- D NanoProtect filter Series 3 (FY2180/30)
- E Back cover

Controls overview (Fig ②)

	Filter cleaning alert		Power on/off button
	Filter replacement alert		Mode switch button
	Filter status/reset button		Light on/off button
	Display switch button		Mode display: Auto (A), Turbo (T), Gentle (G), Sleep (S)

2 Getting started

Installing the filter

Note: Make sure the air purifier is unplugged from the electrical outlet before installing the filter.

- 1 Pull the back cover and remove it from the appliance (fig ③).
- 2 Pull the filter from the appliance (fig ④).
- 3 Remove all packaging materials of the air purification filter (fig ⑤).
- 4 Put the filter back into the appliance (fig ⑥).
- 5 Reattach the back cover (fig ⑦).

Wi-Fi indicator

Wi-Fi icon status	Wi-Fi connection status
Blink in orange	Connecting to the smartphone
Blink in white	Connecting to the router
Stable in white	Connected to the router
Off	Wi-Fi function disabled

Wi-Fi connection

Note:

- Corporate/Enterprise networks (e.g. certificates, network profiles) are not supported. We recommend setting up the Philips Air Purifiers on a dedicated network created for IoT devices or WPA2-Personal networks.
- Configuration details are provided in the Clean Home+ app (e.g. Mac address) to help set-up on managed networks.

First time connection

- 1 Download and install the Philips “**Clean Home+**” app from the **App Store** or **Google Play**.
- 2 Connect your smartphone or tablet to your Wi-Fi network.
- 3 Launch the “**Clean Home+**” app and click on “**Connect a New Device**” or press the “+” button on the top of the screen. Follow the onscreen instructions to connect the air purifier to your network.



Reset the Wi-Fi connection

- 1 Touch  and  for 3 seconds until you hear a beep.
↳ The Wi-Fi indicator  blinks orange.
- 2 Follow the steps 3 in “**First time connection**” section.

Note:

- Enterprise/Additional webpage authentication networks are not supported.
- Please check www.philips.com/cleanhome for the latest update of supported Operation System and devices.

3 Using the air purifier

Air quality light

After approximately 30 seconds, the particle sensor selects the color that corresponds to the surrounding air quality of airborne particles.

Note: The color of the air quality light is determined by the highest risk index among PM2.5 and IAI readings.

IAI refers to the level of indoor air allergen.

IAI level	Air quality light color	Air quality level
1-3	Blue	Good
4-6	Blue-purple	Fair
7-9	Purple-red	Poor
10-12	Red	Very poor



PM2.5 refers to airborne particle pollutants smaller than 2.5 micrometers.

PM2.5 level	Air quality light color	Air quality level
≤12	Blue	Good
13-35	Blue-purple	Fair
36-55	Purple-red	Poor
>55	Red	Very poor

Turning On and Off





Note:

- Put the plug of the air purifier in the power socket.
- If the purifier stays connected to the electrical outlet after turning OFF, the air purifier will operate under the previous settings when turned ON again.

- 1 Touch  to switch on the air purifier (fig 8).
- 2 The “---” displays on the screen during warming up. Then the air purifier shows the IAI/PM2.5 level after measuring the air quality (fig 9).
- 3 The air purifier operates in the auto mode with IAI displayed on the screen (fig 10).
- 4 Touch and hold the  button for 3 seconds to switch off the air purifier (fig 11).

Changing the mode setting

You can choose Auto mode, Turbo mode, Gentle mode or the Sleep mode by touching the  button.

- 1 **Auto mode** (): The air purifier automatically adjusts the fan speed in accordance with the ambient air quality (fig 12).
- 2 **Turbo mode** (): The air purifier operates on the highest speed (fig 13).
- 3 **Gentle mode** (): The air purifier operates at a low speed (fig 14).
- 4 **Sleep mode** (): The air purifier operates quietly at a low speed. After 3 seconds, the screen lights off (fig 15).

Switching the display indicator

Note:

- The appliance display IAI level by default (fig 16 & fig 17).

Using the light on/off function









You can touch the light on/off button  manually to turn off all lights and the control panel. Touch any button to wake up all lights (fig 18 & fig 19).

With the light sensor:

- The control panel can automatically turn on, turn off or dim according to the ambient light.
- The control panel will be off or dim when the ambient light is dark.

You can touch any button to wake up all lights. If no further operation, all lights will be off or dim again to match with the ambient light.

Setting the child lock

- 1 Touch and hold  and  button for 3 seconds to activate child lock. (fig 20).
 - ↳  displays on the screen, only  and  button light up.
 - ↳ After 3 seconds, the screen goes back to normal display.
- 2 Touch and hold  and  button for 3 seconds again to deactivate child lock.(fig 21).
 - ↳  displays on the screen for 3 seconds and goes back to normal display.
 - ↳ All buttons light up.

Checking the filter status

- Touch the filter status check/reset  button to check the filter service life status (fig 22).

Icon color	Display (%)
Blue	16-100
Blue-purple	9-15
Purple-red	4-8
Red	0-3

Note: The appliance goes back to normal display if no operations after 3 seconds.

4 Cleaning and maintenance

Note:

- Do not attempt to clean the particle sensor with a vacuum cleaner.
- Switch off the air purifier and unplug from the power socket before following action.

Cleaning the body of the air purifier

Use a soft, dry cloth to clean both the interior and exterior of the air purifier and the air outlet (fig 23).



Cleaning the particle sensor

Clean the particle sensor every 2 months for optimal functioning of the appliance.

- 1 Clean the particle sensor inlet and outlet with a soft brush (fig 24).
- 2 Clean the particle sensor with a damp cotton swab. Dry all parts thoroughly with a dry cotton swab (fig 25).

Cleaning the surface of the filter

Clean the surface of filter with vacuum cleaner when the filter cleaning alert  display on the screen (fig 26).



- 1 Pull the back cover and remove it from the appliance (fig 3).
- 2 Pull the filter from the appliance (fig 27).
- 3 Clean the surface of the filter with a vacuum cleaner (fig 28).
- 4 Put the filter back into the appliance (fig 6).
- 5 Reattach the back cover (fig 7).
- 6 Touch the  button to switch on the appliance (fig 8).
- 7 Touch and hold the filter status check/reset button  for 3 seconds to reset the filter cleaning time (fig 29).
- 8 Wash your hands thoroughly after cleaning the filter (fig 30).

Replacing the filter

Note:



- The filter is not washable or reusable.
- Do not smell the filter as it has collected pollutants from the air.

When the filter need to be replaced, the filter replacement alert  lights up red (fig 31).

- 1 Replace the filter with Philips NanoProtect filter Series 3 (FY2180/30), Please follow the step of Chapter “Installing the filter”.
- 2 Touch the  button to switch on the appliance (fig 8).
- 3 Touch and hold the filter status check/reset button  for 3 seconds to reset the filter replacement time (fig 32).
- 4 Wash your hands thoroughly after replacing the filter (fig 30).

Filter reset

You can also replace the filter before filter replacement alert () displays on the screen. After replacing a filter, you need to reset the filter lifetime counter manually.

- 1 Touch the power  button for 3 seconds to turn off the appliance and unplug from power socket(fig 8).
- 2 Put the power plug in the power socket (fig 33).
- 3 Within 15 seconds after power on, touch and hold  and  button for 3 seconds to reset the filter lifetime counter (fig 34).

5 Storage

- 1 Turn off the air purifier and unplug from the power socket.
- 2 Clean the air purifier, particle sensor and the surface of the filter (see the chapter “Cleaning and maintenance”).
- 3 Let all parts air dry thoroughly before storing.
- 4 Wrap the filter in air tight plastic bags.
- 5 Store the air purifier, filter in a cool, dry location.
- 6 Always thoroughly wash hands after handling filters.

6 Troubleshooting

This chapter summarizes the most common problems you could encounter with the appliance. If you are unable to solve the problem with the information below, contact the Consumer Care Center in your country.

Problem	Possible solution
The appliance does not work properly.	<ul style="list-style-type: none">• The filter replacement alert has been on continuously but you have not replaced the corresponding filter. As a result, the appliance is now locked. In this case, replace the filter and long press  to reset the filter lifetime counter.
The airflow that comes out of the air outlet is significantly weaker than before.	<ul style="list-style-type: none">• The surface of the filter is dirty. Clean the surface of the filter (see the chapter “Cleaning and maintenance”).

Problem	Possible solution
The air quality does not improve, even though the appliance has been operating for a long time.	<ul style="list-style-type: none">• Check if the packing material is removed from the filter.• The filter has not been placed in the appliance. Make sure that the filter (FY2180/30) is properly installed.• The particle sensor is wet. The humidity level in your room is high and causes condensation. Make sure that the particle sensor is clean and dry (see the chapter “Cleaning and maintenance”).• Room size is large or the outdoor air quality is poor. For optimum purification performance, please close the doors and windows when operating the air purifier.• There are indoor pollution resources. For instances, smoking, cooking, incense, perfume or alcohol.• Filter reaches the end of life. Replace the filter with a new one.
The color of the air quality light always stays the same.	<ul style="list-style-type: none">• The particle sensor is dirty. Clean the particle sensor (see the chapter “Cleaning and maintenance”).
The appliance produces a strange smell.	<ul style="list-style-type: none">• The first few times you use the appliance, it may produce a plastic smell. This is normal. However, if the appliance produces a burnt smell even if removing filters, contact your Philips dealer or an authorized Philips service center. The filter may produce smell after being used for a while because of the absorption of indoor gases. It's recommended that you reactivate the filter by putting it in direct sunlight for repeated use. If odor still exists, replace the filter.

Problem	Possible solution
The appliance is extra loud.	<ul style="list-style-type: none"> • It's normal if the appliance runs at the Turbo mode. • In the Auto mode, if the appliance is too loud, maybe the appliance runs at high speed because air quality becomes worse, or your personalized setting in App triggers a higher fan speed. You can choose the Sleep mode, or change the settings in the App. • If anything drops into air outlet, it may also cause abnormal loud sound. Immediate turn off appliance, turn appliance upside down, to get foreign objectives out of appliance. • If there is abnormal sound, contact the Consumer Care Center in your country.
The appliance still indicates that I need to replace a filter, but I already did.	<ul style="list-style-type: none"> • Perhaps you did not reset the filter lifetime counter. Switch on the appliance. Then touch and hold the reset button () for 3 seconds.
Error code “E1” displays on the screen.	<ul style="list-style-type: none"> • The motor has malfunctions. Contact the Consumer Care Center in your country.

Problem	Possible solution
The Wi-Fi setup is not successful.	<ul style="list-style-type: none">• If the router your purifier is connected to is dual – band and currently it is not connecting to a 2.4GHz network, please switch to another band of the same router (2.4GHz) and try to pair your purifier again. 5GHz networks are not supported. If your purifier is connected to a dual – band router, please switch to the 2.4GHz network of the router and try to pair your purifier again.• Web authentication networks are not supported. Public Wi-Fi such as office or hotel networks are not supported.• Check if the purifier is within range of the Wi-Fi router. You can try to locate the air purifier closer to the Wi-Fi router.• Check if the Wi-Fi password is correct. The password is case-sensitive.• Retry the setup with the instructions in section “Reset the Wi-Fi connection”.• Keep the appliance away from other electronic devices that may cause interferences.• Check if the mobile device is in airplane mode. Make sure to have the airplane mode deactivated when connecting to the Wi-Fi network.• If the Wi-Fi pairing fails after trying several times, please turn off the cellular data on your smartphone in the Settings section and start the pairing again.• If the Wi-Fi icon on your purifier’s display is in stable white but without seeing the purifier in your app, click on “Connect a New Device” and add the purifier from the local list on “Begin setup” page.• Consult the help section in the App for extensive and up-to-date troubleshooting tips.

Indhold

1	Din luftrenser	13
	Produktoversigt (fig. ①)	13
	Oversigt over betjeningsknapper (fig. ②)	13
2	Sådan kommer du i gang	14
	Montering af filteret	14
	Wi-Fi-indikator	14
	Wi-Fi-forbindelse	14
3	Brug af luftrenseren	15
	Luftkvalitetslys	15
	Sådan tændes og slukkes apparatet	16
	Ændring af tilstandsindstillingen	16
	Skift af displayindikator	16
	Sådan bruger du lampens tænd/sluk-funktion	16
	Indstilling af børnesikring	17
	Kontrollér filterets status	17
4	Rengøring og vedligeholdelse	17
	Rengøring af luftrenserens kabinet	17
	Rengøring af partikelsensor	17
	Rengøring af filterets overflade	18
	Udskiftning af filteret	18
	Filternulstilling	18
5	Opbevaring	19
6	Fejlfinding	19

1 Din luftreenser

Tillykke med dit køb af AC2936/AC2939-luftreenser.









For at få fuldt udbytte af den støtte, Philips tilbyder, skal du registrere dit produkt på www.philips.com/welcome.

Produktoversigt (fig. ①)

- A Kontrolpanel
- B Luftudtag
- C Partikelsensor
- D NanoProtect-filter i 3-serien (FY2180/30)
- E Bagdæksel

Dansk

Oversigt over betjeningsknapper (fig. ②)

	Alarm om rengøring af filter		On/off-knap
	Advarsel om udskiftning af filter		Knap til skift af tilstand
	Knap til nulstilling af filterstatus/		Knap til lys til/fra
	Knap til skift af display		Tilstandsvisning: Auto (A), Turbo (T), Blid (B), Sleep (S)

2 Sådan kommer du i gang

Montering af filteret

Bemærk: Sørg for, at stikket til luftrenseren er taget ud af stikkontakten, før filteret monteres.

- 1 Træk i bagdækslet, og fjern det fra apparatet (fig. ③).
- 2 Træk filteret ud af apparatet (fig. ④).
- 3 Fjern alle emballagematerialer fra luftrenserfilteret (fig. ⑤).
- 4 Sæt filteret tilbage i apparatet (fig. ⑥).
- 5 Sæt bagdækslet på igen (fig. ⑦).

Wi-Fi-indikator

Wi-Fi-ikonets status	Wi-Fi-forbindelsesstatus
Blinker orange	Forbinder til smartphone
Blinker hvidt	Oprettelse af forbindelse til routeren
Konstant hvid	Forbindelse er oprettet til routeren
Fra	Wi-Fi-funktion deaktiveret

Wi-Fi-forbindelse

Bemærk:

- Virksomhedsnetværk (f.eks. certifikater, netværksprofiler) understøttes ikke. Vi anbefaler, at du sætter Philips-luftrenseren op på et netværk, der er udviklet til IoT-enheder eller WPA2-Personal-netværk.
- Konfigurationsoplysninger findes i Clean Home+-appen (f.eks. Mac-adresse) for at hjælpe med opsætning på administrerede netværk.

Første tilslutning

- 1 Download og installer Philips “Clean Home+”-appen fra **App Store** eller **Google Play**.
- 2 Slut din smartphone eller tablet til dit Wi-Fi-netværk.
- 3 Start appen “Clean Home+”, og klik på “Connect a New Device” eller tryk på knappen “+” øverst på skærmen. Følg instruktionerne på skærmen for at tilslutte luftrenseren til dit netværk.



Genindstil Wi-Fi-forbindelsen

- 1 Tryk på  og  i 3 sekunder, indtil der lyder et bip.
↳ Wi-Fi-indikatoren  blinker orange.
- 2 Følg trin 3 i afsnittet “Første tilslutning”.

Bemærk:

- Enterprise/yderligere godkendelsesnetværk til websiden understøttes ikke.
- Gå til www.philips.com/cleanhome for at få de seneste oplysninger om understøttede operativsystemer og enheder.

3 Brug af luftrenseren

Luftkvalitetslys

Efter ca. 30 sekunder vælger partikelsensoren den farve, som svarer til den omgivende luftkvalitet af luftbårne partikler.

Bemærk: Farven på luftkvalitetslyset bestemmes af højeste risikofortegnelse blandt aflæsninger af PM2.5 og IAQ.

IAQ henviser til niveauet af indendørs luftallergener.

IAQ-niveau	Luftkvalitetslysets farve	Luftkvalitetsniveau
1-3	Blå	God
4-6	Blå-lilla	Middel
7-9	Lilla-rød	Ringe
10-12	Rød	Meget dårlig



PM2.5 henviser til luftbårne forurenende partikler mindre end 2,5 mikrometer.

PM2.5-niveau	Luftkvalitetslysets farve	Luftkvalitetsniveau
≤ 12	Blå	God
13-35	Blå-lilla	Middel
36-55	Lilla-rød	Ringe
> 55	Rød	Meget dårlig

Sådan tændes og slukkes apparatet





Bemærk:

- Sæt stikket til luftrenseren i stikkontakten.
- Hvis rensere stadig er sluttet til stikkontakten efter slukning, vil den køre under de tidligere indstillinger, når den tændes igen.

- 1 Tryk på  for at tænde for luftrenseren (fig. 8).
- 2 “---” vises på skærmen under opvarmning. Derefter viser luftrenseren IAI/PM2.5-niveauet efter måling af luftkvaliteten (fig. 9).
- 3 Luftrenseren er i automatisk tilstand med IAI vist på skærmen (fig. 10).
- 4 Hold knappen  nede i 3 sekunder for at slukke for luftrenseren (fig. 11).

Ændring af tilstandsindstillingen

Du kan vælge automatisk tilstand, turbotilstand, blid tilstand eller sleep-tilstand ved at trykke på knappen .

- 1 **Automatisk tilstand** (): Luftrenseren juster automatisk blæserens hastighed i henhold til den omgivende luftkvalitet (fig. 12).
- 2 **Turbotilstand** (): Luftrenseren kører med den højeste hastighed (fig. 13).
- 3 **Blid tilstand** (): Luftrenseren kører ved lav hastighed (fig. 14).
- 4 **Sleep-tilstand** (): Luftrenseren kører støjsvagt ved lav hastighed. Efter 3 sekunder slukkes skærmen (fig. 15).

Skift af displayindikator

Bemærk:

- Apparatet viser IAI-niveauet som standard (fig. 16 og fig. 17).

Sådan bruger du lampens tænd/sluk-funktion









Du kan trykke på tænd/slukknappen  manuelt for at slukke alt lys og kontrolpanelet. Tryk på en vilkårlig knap for at vække alle lys (fig. 18 og fig. 19).

Med lyssensor:

- Kontrolpanelet kan automatisk tænde, slukke eller dæmpe lyset afhængigt af det omgivende lys.
- Kontrolpanelet vil være slukket eller blive dæmpet, når det omgivende lys er svagt (mørkt).

Du kan trykke på en vilkårlig knap for at vække alle lys. Hvis der ikke er nogen yderligere handling, slukkes eller dæmpes alle lys igen, så de passer til det omgivende lys.

Indstilling af børnesikring

- Tryk på knapperne  og , og hold dem nede i 3 sekunder for at aktivere børnesikringen (fig. 20).
 - ↳  vises på skærmen, kun knapperne  og  lyser.
 - ↳ Efter 3 sekunder vender skærmen tilbage til normal visning.
- Tryk på knapperne  og  igen, og hold dem nede i 3 sekunder for at deaktivere børnesikringen (fig. 21).
 - ↳  vises på skærmen i 3 sekunder og går tilbage til normal visning.
 - ↳ Alle knapper lyser.

Kontrollér filterets status

- Tryk på knappen for statustjek/nulstilling  for at kontrollere filterets levetid (fig. 22).

Ikonets farve	Display (%)
Blå	16-100
Blå-lilla	9-15
Lilla-rød	4-8
Rød	0-3

Bemærk: Apparatet går tilbage til normal visning efter 3 sekunders inaktivitet.

4 Rengøring og vedligeholdelse

Bemærk:

- Forsøg ikke at rengøre partikelsensoren med en støvsuger.
- Sluk for luftrenseren, og tag stikket ud af stikkontakten, før du gør følgende.

Rengøring af luftrenserens kabinet

Brug en blød, tør klud til at rengøre luftrenseren og luftudtaget både indvendigt og udvendigt (fig. 23).



Rengøring af partikelsensor

Rengør partikelsensoren hver 2. måned for optimal funktion af apparatet.

- Rengør partikelsensoren indløb og udløb med en blød børste (fig. 24).
- Rengør partikelsensoren med en fugtig vatpind. Tør alle dele grundigt med en tør vatpind (fig. 25).

Rengøring af filterets overflade

Rengør overfladen på filter med en støvsuger når alarm om rengøring af filter  vises på skærmen (fig. 26).



- 1 Træk i bagdækslet, og fjern det fra apparatet (fig. 3).
- 2 Træk filteret ud af apparatet (fig. 27).
- 3 Rengør filterets overflade med en støvsuger (fig. 28).
- 4 Sæt filteret tilbage i apparatet (fig. 6).
- 5 Sæt bagdækslet på igen (fig. 7).
- 6 Tryk på knappen  for at tænde for at tænde apparatet (fig. 8).
- 7 Hold knappen for filterstatus/nulstilling  nede i 3 sekunder for at nulstille filterets rengøringstid (fig. 29).
- 8 Vask hænderne grundigt efter rengøring af filteret (fig. 30).

Udskiftning af filteret

Bemærk:



- Filteret må ikke vaskes og heller ikke genbruges.
- Du må ikke lugte til filteret, da det har samlet forurenende stoffer fra luften.

Når filteret skal udskiftes, lyser alarmen om udskiftning af filter  rødt (fig. 31).

- 1 Udskift filteret med et Philips NanoProtect Series 3-filter (FY2180/30). Følg trinene i kapitlet “Montering af filteret”.
- 2 Tryk på knappen  for at tænde for at tænde apparatet (fig. 8).
- 3 Hold knappen  nede i 3 sekunder for at nulstille tidspunkt for udskiftning af filter (fig. 32).
- 4 Vask hænderne grundigt efter udskiftning af filteret (fig. 30).

Filternulstilling

Du kan også udskifte filteret, før alarmen om udskiftning af filter () vises på skærmen. Når du har udskiftet et filter, skal du nulstille filterets levetidstæller manuelt.

- 1 Tryk på tænd/slukknappen  i 3 sekunder for at slukke for apparatet, og tag stikket ud fra stikkontakten (fig. 8).
- 2 Sæt stikket i stikkontakten (fig. 33).
- 3 Inden for 15 sekunder efter opstart skal du holde  og  nede i 3 sekunder for at nulstille filterets levetidstæller (fig. 34).

5 Opbevaring

- 1 Sluk for luftrenseren, og tag stikket ud af stikkontakten.
- 2 Rengør luftrenseren, partikelsensoren og overfladen på filteret (se kapitlet "Rengøring og vedligeholdelse").
- 3 Lad alle dele lufttørre grundigt, før affugteren stilles væk.
- 4 Pak filteret ind i lufttætte plastikposer.
- 5 Opbevar luftrenseren og filteret et køligt, tørt sted.
- 6 Vask altid hænderne grundigt efter håndtering af filtre.

6 Fejlfinding

I dette kapitel beskrives de mest almindelige problemer, der kan opstå med dit apparat. Hvis du ikke kan løse problemet ud fra nedenstående oplysninger, skal du kontakte kundecentret i dit land.

Problem	Mulig løsning
Apparatet fungerer ikke korrekt.	<ul style="list-style-type: none"> • Alarmen for filterskift har været tændt konstant, men du har ikke udskiftet det pågældende filter. Derfor er apparatet nu låst. I dette tilfælde skal du udskifte filteret og holde  nede for at nulstille filterets levetidstæller.
Den luftstrøm, der kommer ud af luftudtaget, er betydeligt svagere end før.	<ul style="list-style-type: none"> • Filterets overflade er beskidt. Rengør filterets overflade (se kapitlet "Rengøring og vedligeholdelse").

Problem	Mulig løsning
Luftkvaliteten forbedres ikke, selvom apparatet har kørt i lang tid.	<ul style="list-style-type: none"> • Kontroller, om emballagen er fjernet fra filtrene. • Filteret er ikke sat i apparatet. Sørg for, at filteret (FY2180/30) er korrekt sat i. • Partikelsensoren er våd. Luftfugtigheden i rummet er høj og forårsager kondens. Sørg for, at partikelsensoren er ren og tør (se afsnittet “Rengøring og vedligeholdelse”). • Rumstørrelsen er stor, eller den udendørs luft af dårlig kvalitet. Optimal rensning af luften opnås ved at lukke døre og vinduer, når du bruger luftrenseren. • Der er indendørs forureningskilder. F.eks. rygning, kogning, røgelse, parfume eller alkohol. • Filterets levetid er ved at udløbe. Udskift filteret med et nyt.
Farven på luftkvalitetslyset er altid den samme.	<ul style="list-style-type: none"> • Partikelsensoren er beskidt. Rengør partikelsensoren (se kapitlet “Rengøring og vedligeholdelse”).
Apparatet frembringer en mærkelig lugt.	<ul style="list-style-type: none"> • De første par gange du anvender apparatet, udsender det muligvis en lugt af plastik. Dette er normalt. Men hvis apparatet afgiver en brændt lugt selv efter fjernelse af filtre, skal du kontakte din Philips-forhandler eller et autoriseret Philips-serviceværksted. Filteret kan afgive lugt, når det har været brugt et stykke tid, pga. absorptionen af indendørs gasser. Det anbefales, at du genaktiverer filteret ved at lægge det i direkte sollys til gentagen brug. Hvis der stadig forekommer lugtgener, skal filteret udskiftes.

Problem	Mulig løsning
Apparatet er ekstra støjende.	<ul style="list-style-type: none">• Det er normalt, hvis apparatet kører i turbotilstand.• Hvis apparatet er for højlydt i automatisk tilstand, kører det måske ved høj hastighed, fordi luftkvaliteten bliver værre, eller dine personlige indstillinger i appen udløser en højere blæserhastighed. Du kan vælge sleep-tilstanden eller ændre indstillingerne i appen.• Hvis noget falder ned i luftudtaget, kan det også forårsage unormal høj lyd. Sluk øjeblikkeligt for apparatet, og vend det på hovedet for at få fremmedlegemer ud.• Hvis der er en unormal lyd, skal du kontakte kundecenteret i dit land.
Apparatet viser stadig, at jeg skal udskifte et filter, men det har jeg allerede gjort.	<ul style="list-style-type: none">• Måske har du ikke nulstillet filterets levetidstæller. Tænd for apparatet. Tryk derefter på nulstillingsknappen (), og hold den nede i 3 sekunder.
Fejlkode "E1" vises på skærmen.	<ul style="list-style-type: none">• Motoren har en funktionsfejl. Kontakt Philips Kundecenter i dit land.

Problem	Mulig løsning
Wi-Fi-opsætning mislykkedes.	<ul style="list-style-type: none"> • Hvis din luftrenser er tilsluttet til en router med dual band og ikke kan oprette forbindelse til et 2,4 GHz netværk, skal du skifte til en anden kanal på den samme router (2,4 GHz) og prøve at parre luftrenseren igen. 5 GHz-netværk understøttes ikke. Hvis luftrenseren er tilsluttet en dual-band-router, skal du skifte til routerens 2,4 GHz-netværk og prøve at parre luftrenseren igen. • Webgodkendelsesnetværk understøttes ikke. Offentlig Wi-Fi som f.eks. kontor- eller hotelnetværk understøttes ikke. • Kontroller, om luftrenseren er inden for Wi-Fi-routers rækkevidde. Du kan lede efter luftrenseren tættere på Wi-Fi-routeren. • Kontroller, om Wi-Fi-adgangskoden er korrekt. Adgangskoden skelner mellem store og små bogstaver. • Prøv at konfigurere igen med instruktionerne i afsnittet "Nulstil Wi-Fi-forbindelse". • Sørg for, at apparatet ikke står tæt på andre elektroniske apparater, som vil kunne skabe interferens. • Kontroller, om den mobile enhed er i flytilstand. Sørg for, at flytilstand er deaktiveret ved tilslutning til Wi-Fi-netværket. • Hvis Wi-Fi-parringen mislykkes efter flere forsøg, skal du slå mobildata fra på din smartphone i afsnittet Indstillinger og starte parringen igen. • Hvis Wi-Fi-ikonet på luftrenserens display er i stabil hvid, men du ikke kan se luftrenseren i din app, skal du klikke på "Tilslut en ny enhed" og tilføje luftrenseren fra den lokale liste på siden "Start opsætning". • I afsnittet Hjælp i appen kan du få omfattende og helt friske tip til fejlfinding.

Inhalt

1	Der Luftreiniger	24
	Produktübersicht (Abb. ①)	24
	Übersicht über die Bedienelemente (Abb. ②)	24
2	Erste Schritte	24
	Einsetzen des Filters	24
	WLAN-Anzeige	25
	WLAN-Verbindung	25
3	Verwenden des Luftreinigers	26
	Luftqualitätsanzeige	26
	Ein- und Ausschalten	26
	Ändern der Modus-Einstellung	27
	Wechseln der Display-Anzeige	27
	Nutzen der Funktion "Licht an/aus"	27
	Einstellen der Kindersicherung	27
	Überprüfen des Filterstatus	28
4	Reinigung und Wartung	28
	Reinigen des Luftreinigergehäuses	28
	Reinigen des Partikelsensors	28
	Reinigen der Oberfläche des Filters	29
	Den Filter austauschen	29
	Filter zurücksetzen	29
5	Aufbewahrung	30
6	Fehlerbehebung	30

1 Der Luftreiniger









Herzlichen Glückwunsch zum Kauf Ihres AC2936/AC2939 Luftreinigers.

Um das Kundendienstangebot von Philips vollständig nutzen zu können, sollten Sie Ihr Produkt hier registrieren: www.philips.com/welcome.

Produktübersicht (Abb. ①)

- A Bedienfeld
- B Luftauslass
- C Partikelsensor
- D NanoProtect-Filter Serie 3 (FY2180/30)
- E Rückseite

Übersicht über die Bedienelemente (Abb. ②)

	Hinweis zur Reinigung des Filters		Ein-/Ausschalter
	Hinweis zum Austausch des Filters		Moduswahlschalter
	Filterstatus/Rückstelltaste		Ein-/Ausschalter für die Anzeigen
	Anzeigewahlschalter		Modusanzeige: Automodus (A), Turbomodus (T), Sanfter Modus (S), Ruhemodus (R)

2 Erste Schritte

Einsetzen des Filters

Hinweis: Vergewissern Sie sich vor dem Einsetzen des Filters, dass der Netzstecker des Luftreinigers aus der Steckdose gezogen ist.

- 1 Ziehen Sie die Rückseite ab, um sie vom Gerät zu entfernen (Abb. ③).
- 2 Entnehmen Sie den Filter aus dem Gerät (Abb. ④).
- 3 Entfernen Sie sämtliche Verpackungsmaterialien von dem Luftreinigungsfilter (Abb. ⑤).
- 4 Setzen Sie den Filter wieder in das Gerät ein (Abb. ⑥).
- 5 Setzen Sie die Rückseite wieder ein (Abb. ⑦).

WLAN-Anzeige

WLAN-Symbolstatus	WLAN-Verbindungsstatus
Blinkt orange	Verbindung zum Smartphone wird aufgebaut
Blinkt weiß	Verbindung zum Router wird hergestellt
Leuchtet weiß	Mit dem Router verbunden
Aus	WLAN-Funktion deaktiviert

WLAN-Verbindung

Hinweis:



- Geschäfts-/Unternehmensnetzwerke (z. B. Zertifikate, Netzwerkprofile) werden nicht unterstützt. Wir empfehlen, die Philips Luftreiniger in einem speziellen Netzwerk einzurichten, das für IoT-Geräte oder persönliche WPA2-Netzwerke bestimmt ist.
- Informationen zur Konfiguration finden Sie in der Clean Home+ App (z. B. Mac-Adresse), um verwaltete Netzwerke einzurichten.

Erstverbindung

- 1 Laden Sie die Philips **“Clean Home+”** App aus dem **App Store** oder **Google Play** herunter und installieren Sie sie.
- 2 Verbinden Sie Ihr Smartphone oder Tablet mit Ihrem WLAN-Netzwerk.
- 3 Starten Sie die **“Clean Home+”** App, und klicken Sie auf **“Neues Gerät verbinden”** oder drücken Sie auf die **“+”**-Schaltfläche am oberen Rand des Bildschirms. Befolgen Sie die Anweisungen auf dem Bildschirm, um den Luftreiniger mit Ihrem Netzwerk verbinden.



Setzen Sie die WLAN-Verbindung zurück

- 1 Berühren Sie  und  3 Sekunden lang, bis ein Signalton zu hören ist.
↳ Die WLAN-Anzeige  blinkt orange.
- 2 Befolgen Sie Schritt 3 im Abschnitt **“Erstverbindung”**.

Hinweis:

- Web-Authentifizierungen von zusätzlichen oder Unternehmensnetzwerken werden nicht unterstützt.
- Unter www.philips.com/cleanhome finden Sie das neueste Update für unterstützte Betriebssysteme und Geräte.

3 Verwenden des Luftreinigers

Luftqualitätsanzeige

Nach etwa 30 Sekunden zeigt der Partikelsensor dann die Farbe an, die dem Partikelgehalt der Luft in der Umgebung des Geräts entspricht.

Hinweis: Die Farbe der Luftqualitätsanzeige ist vom höchsten Stand der PM2,5- und IAI-Werte abhängig.

IAI steht für den Wert des Innenraumallergene-Index.

IAI-Wert	Farbe der Luftqualitätsanzeige	Luftqualität
1 bis 3	Blau	Gut
4 bis 6	Blau-Violett	Mittelmäßig
7 bis 9	Violett-Rot	Schlecht
10 bis 12	Rot	Sehr schlecht







PM2,5 steht für Schmutzpartikel in der Luft, die kleiner als 2,5 Mikrometer sind.

PM2,5-Wert	Farbe der Luftqualitätsanzeige	Luftqualität
≤ 12	Blau	Gut
13 bis 35	Blau-Violett	Mittelmäßig
36 bis 55	Violett-Rot	Schlecht
> 55	Rot	Sehr schlecht

Ein- und Ausschalten









Hinweis:

- Stecken Sie den Stecker des Luftreinigers in die Steckdose.
- Wenn der Netzstecker des Luftreinigers nach dem Ausschalten nicht aus der Steckdose gezogen wird, nimmt das Gerät beim nächsten Einschalten den Betrieb basierend auf den letzten Einstellungen auf.

- 1 Berühren Sie , um den Luftreiniger einzuschalten (Abb. ).
- 2 “---” wird während des Aufwärmens angezeigt. Nach Messung der Luftqualität wird der Wert für IAI/PM2,5 angezeigt (Abb. ).
- 3 Der Luftreiniger wird im Automodus betrieben, wobei der IAI-Wert in der Mitte der Anzeige angezeigt wird (Abb. ).
- 4 Halten Sie die Taste  3 Sekunden lang gedrückt, um den Luftreiniger auszuschalten (Abb. ).

Ändern der Modus-Einstellung

Durch Berühren der Taste  können Sie zwischen Auto-, Turbo-, Sanfter und Ruhemodus wechseln.



- 1 **Automodus** (): Der Luftreiniger wählt die Lüftergeschwindigkeit automatisch gemäß der Qualität der Umgebungsluft. (Abb. ).
- 2 **Turbomodus** (): Der Luftreiniger wird mit der höchsten Geschwindigkeit betrieben (Abb. ).
- 3 **Sanfter Modus** (): Der Luftreiniger wird mit niedriger Lüftergeschwindigkeit betrieben (Abb. ).
- 4 **Ruhemodus** (): Der Luftreiniger wird leise und mit sehr niedriger Lüftergeschwindigkeit betrieben. Nach 3 Sekunden, leuchtet die Anzeige auf (Abb. ).

Wechseln der Display-Anzeige

Hinweis:

- Die Anzeige des Geräts zeigt standardmäßig die IAI-Werte an (Abb.  und Abb. .

Nutzen der Funktion “Licht an/aus”







Sie können die Taste “Licht an/aus”  berühren, um alle Lichter sowie das Bedienfeld auszuschalten. Durch das Berühren einer beliebigen Taste werden alle Lichter aktiviert (Abb.  und Abb. .



Der Lichtsensor:

- Das Bedienfeld kann sich automatisch einschalten, ausschalten oder dimmen, je nach Umgebungslicht.
- Das Bedienfeld wird ausgeschaltet oder gedimmt, wenn das Umgebungslicht gering ist.

Durch das Berühren einer beliebigen Taste werden alle Lichter aktiviert. Wenn keine weiteren Aktionen erfolgen, werden alle Lichter ausgeschaltet oder gedimmt, um sich dem Umgebungslicht anzupassen.

Einstellen der Kindersicherung

- 1 Halten Sie die  und  Taste 3 Sekunden lang gedrückt, um die Kindersicherung zu aktivieren (Abb. ).
 - ↳  wird auf dem Bildschirm angezeigt, nur die  und  Tasten leuchtet auf.
 - ↳ Nach 3 Sekunden kehrt der Bildschirm wieder zur normalen Anzeige zurück.

- Halten Sie die  und  erneut 3 Sekunden lang gedrückt, um die Kindersicherung wieder zu deaktivieren (Abb. 21).
 - ↳  wird 3 Sekunden lang auf dem Bildschirm angezeigt und kehrt zur normalen Anzeige zurück.
 - ↳ Alle Tasten leuchten auf.

Überprüfen des Filterstatus

- Berühren Sie die Filterstatus-/Rückstell Taste , um den Filterstatus zu überprüfen (Abb. 22).

Symbolfarbe	Anzeige (%)
Blau	16 bis 100
Blau-Violett	9 bis 15
Violett-Rot	4 bis 8
Rot	0 bis 3

Hinweis: Wenn nach 3 Sekunden keine weiteren Schritte durchgeführt werden, wird die normale Anzeige wieder angezeigt.

4 Reinigung und Wartung

Hinweis:

- Versuchen Sie nicht, den Partikelsensor mit dem Staubsauger zu reinigen.
- Schalten Sie den Luftreiniger aus und ziehen Sie den Netzstecker aus der Steckdose bevor Sie die folgenden Schritte ausführen.

Reinigen des Luftreinigergehäuses

Säubern Sie das Innere und Äußere des Luftreinigers und den Luftauslass mit einem weichen, trockenen Tuch (Abb. 23).



Reinigen des Partikelsensors

Reinigen Sie den Partikelsensor alle 2 Monate, um die ideale Funktion des Geräts sicherzustellen.

- Reinigen Sie den Ein- und Auslass des Partikelsensor mit einer weichen Bürste (Abb. 24).
- Reinigen Sie den Partikelsensor mit einem feuchten Wattestäbchen. Trocknen Sie alle Teile gründlich mit einem trockenen Wattestäbchen ab (Abb. 25).

Reinigen der Oberfläche des Filters

Reinigen Sie die Oberfläche des Filters mit einem Staubsauger, wenn der Hinweis zur Reinigung des Filters  auf der Anzeige erscheint (Abb. 26).



- 1 Ziehen Sie die Rückseite ab, um sie vom Gerät zu entfernen (Abb. 3).
- 2 Entnehmen Sie den Filter aus dem Gerät (Abb. 27).
- 3 Reinigen Sie die Oberfläche des Filters mit einem Staubsauger (Abb. 28).
- 4 Setzen Sie den Filter wieder in das Gerät ein (Abb. 6).
- 5 Setzen Sie die Rückseite wieder ein (Abb. 7).
- 6 Berühren Sie die Taste , um das Gerät einzuschalten (Abb. 8).
- 7 Halten Sie die Filterstatus-/Rückstell Taste  3 Sekunden lang gedrückt, um die Reinigungszeit des Filters zurückzusetzen (Abb. 29).
- 8 Waschen Sie sich nach dem Reinigen des Filters gründlich die Hände (Abb. 30).

Den Filter austauschen

Hinweis:



- Der Filter ist weder abwaschbar noch wiederverwendbar.
- Riechen Sie nicht am Filter, da dieser Schadstoffe aus der Luft gesammelt hat.

Wenn der Filter ausgetauscht werden muss, leuchtet die Kontrollanzeige zum Austauschen des Filters  rot auf (Abb. 31).

- 1 Tauschen Sie den Filter mit einem Philips NanoProtect-Filter der Serie 3 aus (FY2180/30) und befolgen Sie die Schritte im Kapitel "Einsetzen des Filters".
- 2 Berühren Sie die Taste , um das Gerät einzuschalten (Abb. 8).
- 3 Halten Sie die  -Taste 3 Sekunden lang gedrückt, um die Filterstandzeit zurückzusetzen (Abb. 32).
- 4 Waschen Sie sich nach dem Auswechseln des Filters gründlich die Hände (Abb. 30).

Filter zurücksetzen

Sie können den Filter auch bereits austauschen, bevor die Kontrollanzeige zum Austauschen des Filters () aufleuchtet. Nach dem Austauschen eines Filters müssen Sie den Zähler für die Filterstandzeit manuell zurücksetzen.

- 1 Drücken Sie die  Ein-/Ausschalttaste für 3 Sekunden, um das Gerät auszuschalten, und ziehen Sie den Netzstecker aus der Steckdose (Abb. 8).
- 2 Stecken Sie den Netzstecker in die Steckdose (Abb. 33).
- 3 Halten Sie innerhalb von 15 Sekunden nach dem Einschalten die Tasten  und  3 Sekunden lang gedrückt, um den Zähler für die Filterstandzeit zurückzusetzen (Abb. 34).

5 Aufbewahrung

- 1 Schalten Sie den Luftreiniger aus, und ziehen Sie den Netzstecker aus der Steckdose.
- 2 Reinigen Sie den Luftreiniger, den Partikelsensor und die Oberfläche des Filters (siehe Kapitel "Reinigung und Wartung").
- 3 Lassen Sie alle Teile vor der Aufbewahrung gründlich an der Luft trocknen.
- 4 Wickeln Sie den Filter in luftdichte Plastiktüten.
- 5 Bewahren Sie den Luftreiniger und den Filter an einem kühlen, trockenen Ort auf.
- 6 Waschen Sie sich nach jedem Kontakt mit den Filtern gründlich die Hände.

6 Fehlerbehebung

In diesem Kapitel sind die häufigsten Probleme aufgeführt, die beim Gebrauch Ihres Geräts auftreten können. Sollten Sie ein Problem mithilfe der nachstehenden Informationen nicht beheben können, wenden Sie sich bitte an das Philips Service-Center in Ihrem Land.

Problem	Mögliche Lösung
Das Gerät funktioniert nicht ordnungsgemäß.	<ul style="list-style-type: none">• Die Filterwechselanzeige leuchtet bereits seit längerer Zeit ununterbrochen, doch Sie haben den entsprechenden Filter nicht ausgewechselt. Das Gerät ist nun gesperrt. Wechseln Sie in diesem Fall den Filter aus, und drücken Sie lange auf , um den Zähler für die Filterstandzeit zurückzusetzen.
Der Luftstrom, der aus dem Luftauslass dringt, ist bedeutend schwächer als vorher.	<ul style="list-style-type: none">• Die Oberfläche des Filters ist schmutzig. Reinigen Sie die Oberfläche des Filters (siehe Kapitel "Reinigung und Wartung").

Problem	Mögliche Lösung
Die Luftqualität verbessert sich nicht, obwohl das Gerät lange Zeit in Betrieb war.	<ul style="list-style-type: none">• Überprüfen Sie, ob das Verpackungsmaterial vom Filter entfernt wurde.• Der Filter wurde nicht in das Gerät eingesetzt. Vergewissern Sie sich, dass der Filter (FY2180/30) ordnungsgemäß eingesetzt wurde.• Der Partikelsensor ist nass. Die Luftfeuchtigkeit im Raum ist hoch und verursacht Kondensation. Stellen Sie sicher, dass der Partikelsensor sauber und trocken ist (siehe Kapitel "Reinigung und Wartung").• Der Raum ist sehr groß oder die Qualität der Luft im Freien ist mangelhaft. Um von einer optimalen Luftreinigung zu profitieren, schließen Sie bitte Türen und Fenster, wenn Sie den Luftreiniger verwenden.• Luft kann auch drinnen verschmutzt werden. Beispielsweise durch Rauchen, Kochen, Räucherstäbchen, Parfüm oder Alkohol.• Der Filter hat das Ende seiner Lebensdauer erreicht. Ersetzen Sie den Filter durch einen neuen Filter.
Die Farbe der Luftqualitätsanzeige ändert sich nicht.	<ul style="list-style-type: none">• Der Partikelsensor ist verschmutzt. Reinigen Sie den Partikelsensor (siehe Kapitel "Reinigung und Wartung").
Bei dem Gerät tritt ein ungewöhnlicher Geruch auf.	<ul style="list-style-type: none">• Anfangs kann das Gerät einen leichten Kunststoffgeruch verströmen. Das ist normal. Wenn das Gerät auch nach Entfernung der Filter einen verbrannten Geruch verströmt, wenden Sie sich an einen Philips Händler oder ein autorisiertes Philips Service-Center. Unter Umständen produziert der Filter aufgrund der Aufnahme von Innenraumgasen einen unangenehmen Geruch, wenn er längere Zeit verwendet wurde. Es wird empfohlen, dass Sie ihn reaktivieren, indem Sie ihn bei regelmäßiger Verwendung in direktes Sonnenlicht stellen. Wenn der Geruch weiterhin besteht, ersetzen Sie den Filter.

Problem	Mögliche Lösung
Das Gerät ist sehr laut.	<ul style="list-style-type: none"> • Das ist normal, wenn der Turbomodus aktiviert ist. • Wenn das Gerät im automatischen Modus zu laut ist, kann es sein, dass das Gerät auf der höchsten Geschwindigkeitsstufe läuft, weil die Luftqualität ansonsten abnimmt, oder dass Ihre individuelle Einstellung in der App für eine höhere Ventilatorgeschwindigkeit sorgt. Wechseln Sie entweder in den Sleep-Modus, oder ändern Sie die Einstellungen in der App. • Anormale Geräusche können auch durch Gegenstände verursacht werden, die versehentlich in den Luftaustritt gelangen. Schalten Sie das Gerät umgehend aus, und drehen Sie es herum, um die Gegenstände herauszuholen. • Wenn anormale Geräusche auftreten, setzen Sie sich bitte mit einem Service-Center in Ihrem Land in Verbindung.
Das Gerät zeigt an, dass ich einen Filter auswechseln muss, obwohl ich dies schon gemacht habe.	<ul style="list-style-type: none"> • Sie haben möglicherweise den Zähler für die Filterlebensdauer nicht zurückgesetzt. Schalten Sie das Gerät ein. Halten Sie die Reset-Taste () 3 Sekunden lang gedrückt.
Der Fehlercode "E1" wird auf dem Display angezeigt.	<ul style="list-style-type: none"> • Der Motor funktioniert nicht ordnungsgemäß. Wenden Sie sich an den Philips Kundendienst in Ihrem Land.

Problem	Mögliche Lösung
Die WLAN-Einrichtung ist nicht erfolgreich.	<ul style="list-style-type: none">• Wenn der Router, mit dem Ihr Luftreiniger verbunden ist, ein Dualband-Router ist, und Ihr Luftreiniger aktuell keine Verbindung mit einem 2,4-GHz-Netzwerk herstellt, wechseln Sie auf ein anderes Frequenzband desselben Routers (2,4 GHz), und versuchen Sie dann erneut, Ihren Luftreiniger zu koppeln. 5-GHz-Netzwerke werden nicht unterstützt. Wenn Ihr Luftreiniger mit einem Dualband-Router verbunden ist, wechseln Sie zum 2,4-GHz-Netzwerk des Routers und versuchen Sie dann erneut, den Luftreiniger zu koppeln.• Web-Authentifizierungsnetzwerke werden nicht unterstützt. Öffentliche WLAN-Netzwerke wie z. B. in Büros oder Hotels werden nicht unterstützt.• Überprüfen Sie, ob der Luftreiniger sich innerhalb der Reichweite des WLAN-Routers befindet. Sie können versuchen, den Luftreiniger näher am WLAN-Router zu platzieren.• Überprüfen Sie, ob das WLAN-Passwort korrekt ist. Beachten Sie bei der Eingabe des Passworts die Groß- und Kleinschreibung.• Wiederholen Sie die Einrichtung mit den Anweisungen im Abschnitt "WLAN-Verbindung zurücksetzen".• Halten Sie das Gerät von anderen elektronischen Geräten fern, um Störsignale zu vermeiden.• Überprüfen Sie, ob sich das Mobilgerät im Flugmodus befindet. Stellen Sie sicher, dass der Flugmodus deaktiviert ist, wenn eine Verbindung mit dem WLAN-Netzwerk hergestellt wird.• Wenn die WLAN-Kopplung nach mehreren Versuchen fehlschlägt, schalten Sie die Mobilfunkdaten auf Ihrem Smartphone unter "Einstellungen" aus und starten Sie die Kopplung erneut.• Wenn das WLAN-Symbol auf dem Display Ihres Luftreinigers weiß leuchtet, er in Ihrer App aber nicht angezeigt wird, klicken Sie auf "Neues Gerät anschließen" und fügen Sie den Luftreiniger aus der lokalen Liste unter "Einrichtung starten" hinzu.• Im Hilfeabschnitt der App finden Sie umfassende und aktuelle Tipps zur Fehlerbehebung.

Contenido

1	Purificador de aire	35
	Descripción del producto (fig. ①)	35
	Descripción de los controles (fig. ②)	35
2	Introducción	35
	Instalación del filtro	35
	Indicador de Wi-Fi	36
	Conexión Wi-Fi	36
3	Uso del purificador de aire	37
	Piloto de calidad del aire	37
	Encendido y apagado	37
	Cambio de la configuración de modo	38
	Cambiar el indicador de visualización	38
	Uso de la función de encendido/apagado del piloto	38
	Configuración del bloqueo infantil	38
	Comprobación del estado del filtro	39
4	Limpieza y mantenimiento	39
	Limpieza del cuerpo del purificador de aire	39
	Limpieza del sensor de partículas	39
	Limpieza de la superficie del filtro	40
	Sustitución del filtro	40
	Restablecimiento de filtros	40
5	Almacenamiento	41
6	Solución de problemas	41

1 Purificador de aire

Enhorabuena por la adquisición del filtro de aire AC2936/AC2939.

Para poder beneficiarse por completo de la asistencia que ofrece Philips, registre el producto en www.philips.com/welcome.

Descripción del producto (fig. ①)

- A Panel de control
- B Salida de aire
- C Sensor de partículas
- D Filtro NanoProtect serie 3 (FY2180/30)
- E Cubierta posterior

Descripción de los controles (fig. ②)

	Alerta de limpieza del filtro		Botón de encendido/apagado
	Alerta de sustitución del filtro		Botón de conmutador de modo
	Botón de reinicio/estado del filtro		Botón de encendido/apagado del piloto
	Botón de conmutador de visualización		Visualización de modo: Automático (A), Turbo (T), Suave (S), Reposo (R)

2 Introducción

Instalación del filtro

Nota: Asegúrese de que el purificador de aire está desenchufado de la toma de corriente eléctrica antes de instalar el filtro.

- 1 Tire de la cubierta posterior y retírela del aparato (fig. ③).
- 2 Tire del filtro NanoProtect para retirarlo del aparato (fig. ④).
- 3 Retire todo el embalaje del filtro de purificación del aire (fig. ⑤).
- 4 Ponga el filtro de nuevo en el aparato (fig. ⑥).
- 5 Vuelva a colocar la cubierta posterior (fig. ⑦).

Indicador de Wi-Fi

Estado del icono de Wi-Fi	Estado de la conexión Wi-Fi
Parpadeo en naranja	Conectándose al smartphone
Parpadeo en blanco	Conectando con el router
Estable en blanco	Conectado con el router
Desactivado	Función Wi-Fi desactivada

Conexión Wi-Fi

Nota:



- Las redes corporativas/empresariales (p. ej., certificados, perfiles de red) no son compatibles. Le recomendamos configurar los purificadores de aire Philips en una red específica creada para dispositivos IoT o redes WPA2-Personal.
- Los detalles de configuración se proporcionan en la aplicación Clean Home+ (p. ej. la dirección Mac) para ayudar a configurar redes gestionadas.

Primera conexión

- 1 Descargue e instale la aplicación Philips “Clean Home+” desde **App Store** o **Google Play**.
- 2 Conecte el smartphone o la tableta a su red Wi-Fi.
- 3 Abra la aplicación **Clean Home+** y haga clic en “**Conectar un nuevo dispositivo**” o pulse el botón + en la parte superior de la pantalla. Siga las instrucciones que aparecen en pantalla para conectar el purificador de aire a la red.



Restablecer la conexión Wi-Fi

- 1 Toque  y  durante 3 segundos hasta que oiga un pitido.
↳ El indicador Wi-Fi  parpadea en naranja.
- 2 Siga los pasos 1-3 de la sección “**Primera conexión**”.

Nota:

- Las redes de autenticación de páginas web de empresa/adicionales no son compatibles.
- Visite www.philips.com/cleanhome para obtener información sobre la última actualización de sistemas operativos y dispositivos compatibles.

3 Uso del purificador de aire

Piloto de calidad del aire

Después de aproximadamente 30 segundos, el sensor de partículas selecciona el color que corresponde a la calidad del aire del entorno y sus partículas en suspensión.

Nota: El color del piloto de calidad del aire lo determina el índice de riesgo más alto entre las lecturas de PM2,5 y IAI.

IAI se refiere al nivel de alérgeno de interior.

Nivel IAI	Color del piloto de calidad del aire	Nivel de calidad del aire
1-3	Azul	Bueno
4-6	Azul-morado	Aceptable
7-9	Morado-rojo	Deficiente
10-12	Rojo	Muy malo







PM2,5 se refiere a las partículas aéreas contaminantes inferiores a 2,5 micras.

Nivel de PM2,5	Color del piloto de calidad del aire	Nivel de calidad del aire
≤12	Azul	Bueno
13-35	Azul-morado	Aceptable
36-55	Morado-rojo	Deficiente
>55	Rojo	Muy malo

Encendido y apagado





Nota:

- Enchufe la clavija del purificador de aire a la toma de corriente.
- Si el purificador se mantiene enchufado a la toma de corriente después de apagarlo, seguirá funcionando con la misma configuración cuando vuelva a encenderse.

- 1 Toque  para encender el purificador de aire (fig. .
- 2 Aparece “---” en la pantalla durante el calentamiento. A continuación, el purificador de aire muestra el nivel de IAI/PM2,5 después de medir la calidad del aire (fig. .
- 3 El purificador de aire funciona en modo automático y en la pantalla se muestra el nivel de IAI (fig. .
- 4 Mantenga pulsado el botón  durante 3 segundos para apagar el purificador de aire (fig. .

Cambio de la configuración de modo

Puede elegir el modo automático, el modo turbo, el modo suave o el modo reposo tocando el botón .



- 1 **Modo automático** (.
- 2 **Modo turbo** (.
- 3 **Modo suave** (.
- 4 **Modo de reposo** (.

Cambiar el indicador de visualización

Nota:

- El aparato muestra el nivel IAI de forma predeterminada (fig.  y fig. .

Uso de la función de encendido/apagado del piloto







Puede tocar el botón de encendido de la luz  manualmente para apagar todas las luces y el panel de control. Toque cualquier botón para activar todas las luces (fig.  y fig. .



Con el sensor de luz:

- El panel de control puede encenderse, apagarse o atenuarse automáticamente en función de la iluminación ambiental.
- El panel de control se apagará o atenuará cuando la iluminación ambiental sea oscura.

Puede tocar cualquier botón para activar todas las luces. Si el aparato no se utiliza, todas las luces se apagarán o atenuarán de nuevo según la iluminación ambiental.

Configuración del bloqueo infantil

- 1 Mantenga pulsados los botones  y  durante 3 segundos para activar el bloqueo infantil (fig. ).
 - ↳  se muestra en la pantalla; solo se iluminan los botones  y .
 - ↳ Tras 3 segundos, vuelve a la pantalla normal.

- Mantenga pulsados los botones  y  durante 3 segundos de nuevo para desactivar el bloqueo infantil (fig. 21).
 - ↳  se muestra en la pantalla durante 3 segundos y vuelve a la pantalla normal.
 - ↳ Se iluminan todos los botones.

Comprobación del estado del filtro

- Toque el botón de reinicio/comprobación del estado del filtro  para comprobar el estado de vida útil del filtro (fig. 22).

Color del icono	Pantalla (%)
Azul	16-100
Azul-morado	9 - 15
Morado-rojo	4-8
Rojo	0-3

Nota: El aparato vuelve a la pantalla normal si no se realizan operaciones durante 3 segundos.

4 Limpieza y mantenimiento

Nota:

- No intente limpiar el sensor de partículas con un aspirador.
- Apague el purificador de aire y desconéctelo de la toma de corriente antes de llevar a cabo ninguna acción.

Limpieza del cuerpo del purificador de aire

Utilice un paño suave y seco para limpiar tanto el exterior como el interior del purificador de aire y la salida de aire (fig. 23).



Limpieza del sensor de partículas

Limpie el sensor de partículas cada 2 meses para obtener un funcionamiento óptimo del aparato.

- Limpie la entrada y la salida del sensor de partículas del aire con un cepillo suave (fig. 24).
- Limpie el sensor de partículas con un bastoncillo de algodón húmedo. Seque todas las piezas bien con un bastoncillo de algodón seco (fig. 25).

Limpeza de la superficie del filtro

Limpe la superficie del filtro con un aspirador cuando aparezca la alerta de limpieza del filtro  en la pantalla (fig. 26).



- 1 Tire de la cubierta posterior y retirela del aparato (fig. 3).
- 2 Tire del filtro NanoProtect para retirarlo del aparato (fig. 27).
- 3 Limpe la superficie del filtro con un aspirador (fig. 28).
- 4 Ponga el filtro de nuevo en el aparato (fig. 6).
- 5 Vuelva a colocar la cubierta posterior (fig. 7).
- 6 Toque el botón  para encender el aparato (fig. 8).
- 7 Mantenga pulsado el botón de reinicio/comprobación del estado del filtro  durante 3 segundos para reiniciar el tiempo de limpieza del filtro (fig. 29).
- 8 Lávese bien las manos después de limpie el filtro (fig. 30).

Sustitución del filtro

Nota:



- El filtro no es lavable ni reutilizable.
- No huela el filtro, dado que se ha utilizado para recoger agentes contaminantes del aire.

Cuando se deba sustituir el filtro, la alerta de sustitución del filtro  se iluminará en rojo (fig. 31).

- 1 Sustituya el filtro por el filtro NanoProtect serie 3 de Philips (FY2180/30). siga el paso del capítulo “Instalación del filtro”.
- 2 Toque el botón  para encender el aparato (fig. 8).
- 3 Mantenga pulsado el botón  durante tres segundos para reiniciar el tiempo de sustitución del filtro (fig. 32).
- 4 Lávese bien las manos después de sustituir el filtro (fig. 30).

Restablecimiento de filtros

También puede sustituir el filtro antes de que la alerta de sustitución del filtro () se muestre en la pantalla. Después de sustituir el filtro, debe restablecer el contador de vida útil del filtro manualmente.

- 1 Toque el botón de encendido  durante 3 segundos para apagar el aparato y desenchúfelo de la toma de corriente (fig. 8).
- 2 Introduzca la clavija en la toma de corriente (fig. 33).
- 3 Antes de 15 segundos tras el encendido, mantenga pulsados los botones  y  durante 3 segundos para reiniciar el contador de vida útil del filtro (fig. 34).

5 Almacenamiento

- 1 Apague y desconecte el purificador de aire de la toma de corriente.
- 2 Limpie el purificador de aire, el sensor de partículas y la superficie del filtro (consulte el capítulo “Limpieza y mantenimiento”).
- 3 Deje que todas las piezas se sequen bien antes de guardarlas.
- 4 Introduzca el filtro en una bolsa de plástico hermética.
- 5 Guarde el purificador de aire y el filtro en un lugar fresco y seco.
- 6 Lávese siempre bien las manos después de manipular los filtros.

6 Solución de problemas

Este capítulo resume los problemas más comunes que podría encontrarse con el aparato. Si no puede resolver el problema con la información que aparece a continuación, póngase en contacto con el Servicio de Atención al Cliente en su país.

Problema	Posible solución
El aparato no funciona correctamente.	<ul style="list-style-type: none">• La alerta de sustitución del filtro ha estado encendida de forma continua, pero no ha sustituido el filtro correspondiente. Ahora, como resultado, el aparato está bloqueado. En este caso, sustituya el filtro y mantenga pulsado  para reiniciar el contador de vida útil del filtro.
El flujo de aire procedente de la salida de aire es mucho más débil que anteriormente.	<ul style="list-style-type: none">• La superficie del filtro está sucia. Limpie la superficie del filtro (consulte el capítulo “Limpieza y mantenimiento”).

Problema	Posible solución
La calidad del aire no mejora a pesar de que el aparato lleva funcionando bastante tiempo.	<ul style="list-style-type: none"> • Compruebe si se ha retirado el material de embalaje del filtro. • El filtro no se ha colocado en el aparato. Asegúrese de que el filtro (FY2180/30) está instalado correctamente. • El sensor de partículas está mojado. El nivel de humedad de la habitación es elevado y provoca que el agua se condense. Asegúrese de que el sensor de partículas está limpio y seco (consulte la sección “Limpieza y mantenimiento”). • El tamaño de la habitación es grande o la calidad del aire exterior es deficiente. Para que el rendimiento de purificación sea óptimo, cierre las puertas y ventanas cuando utilice el purificador de aire. • Hay fuentes de contaminación en el interior. Por ejemplo, humo de tabaco, de la cocina, incienso, perfume o alcohol. • El filtro ha llegado al final de su vida útil. Sustituya el filtro por uno nuevo.
El color del piloto de calidad del aire siempre permanece igual.	<ul style="list-style-type: none"> • El sensor de partículas está sucio. Limpie el sensor de partículas (consulte el capítulo “Limpieza y mantenimiento”).
Sale un olor extraño del aparato.	<ul style="list-style-type: none"> • Las primeras veces que use el aparato puede oler a plástico. Esto es normal. Sin embargo, si el aparato produce un olor a quemado incluso después de retirar los filtros, póngase en contacto con su distribuidor Philips o con un centro de servicio Philips autorizado. El filtro puede producir un olor después de ser utilizado durante un período de tiempo debido a la absorción de gases interiores. Se recomienda volver a activar el filtro colocándolo de cara a la luz solar directa para usarlo de forma continuada. Si el olor persiste, sustituya el filtro.

Problema	Posible solución
El aparato hace demasiado ruido.	<ul style="list-style-type: none"> • Es normal si el aparato se utiliza en modo turbo. • En el modo automático, si el aparato hace demasiado ruido, puede que esté funcionando a alta velocidad porque la calidad del aire ha empeorado o que su configuración personalizada en la aplicación haya activado una velocidad del ventilador más alta. Puede elegir el modo reposo o cambiar la configuración en la aplicación. • Si cae algo dentro de la salida de aire, puede que se produzca un sonido alto anormal. Apague inmediatamente el aparato, dele la vuelta y extraiga los objetos extraños del aparato. • Si el sonido es anormal, póngase en contacto con el servicio de atención del cliente de su país.
El aparato aún indica que necesito sustituir un filtro, pero ya lo he hecho.	<ul style="list-style-type: none"> • Puede que no haya reiniciado el contador de vida útil del filtro. Encienda el aparato. A continuación, mantenga pulsado el botón de reinicio (🔄) durante 3 segundos.
En la pantalla se muestra el código de error "E1".	<ul style="list-style-type: none"> • El motor no funciona bien. Póngase en contacto con el servicio de atención al cliente de su país.

Problema	Posible solución
<p>La configuración de la conexión Wi-Fi no se ha realizado correctamente.</p>	<ul style="list-style-type: none"> • Si el router al que está conectado su purificador es de doble banda y en estos momentos no está conectado a una red de 2,4 GHz, intente conectarse a otra banda del mismo router (2,4 GHz) y vuelva a probar a emparejar el purificador. Las redes de 5 GHz no son compatibles. Si el purificador está conectado a un router de doble banda, cambie a la red de 2,4 GHz del router e intente emparejar el purificador de nuevo. • Las redes de autenticación web no son compatibles. No se admite Wi-Fi pública, como redes de oficinas u hoteles. • Compruebe si el purificador se encuentra dentro del alcance del router Wi-Fi. Puede tratar de colocar el purificador de aire más cerca del router Wi-Fi. • Compruebe si la contraseña de la conexión Wi-Fi es correcta. La contraseña distingue entre mayúsculas y minúsculas. • Vuelva a intentar la configuración siguiendo las instrucciones de la sección “Restablecer conexión Wi-Fi”. • Mantenga el aparato alejado de otros dispositivos electrónicos que pueden provocar interferencias. • Compruebe si el dispositivo se encuentra en modo avión. Asegúrese de desactivar el modo avión cuando se conecte a la red Wi-Fi. • Si el emparejamiento Wi-Fi falla después de intentarlo varias veces, active los datos móviles del smartphone en la sección Configuración y vuelva a iniciar el emparejamiento. • Si el icono de Wi-Fi de la pantalla del purificador está en blanco estable pero sin ver el purificador en la aplicación, haga clic en “Conectar un nuevo dispositivo” y añada el purificador de la lista local en la página “Iniciar configuración”. • Consulte la sección de ayuda de la aplicación para obtener más información y consejos actualizados sobre la solución de problemas.

Sisältö

1	Ilmanpuhdistimesi	46
	Tuotteen yleiskuvaus (kuva ①)	46
	Säätimien yleiskuvaus (kuva ②)	46
2	Alkutoimet	46
	Suodattimen asentaminen	46
	Wi-Fi-merkkivalo	47
	Wi-Fi-yhteys	47
3	Ilmanpuhdistimen käyttäminen	48
	Ilmanlaadun merkkivalo	48
	Virran kytkeminen ja katkaiseminen	48
	Tila-asetuksen vaihtaminen	49
	Näyttötilan vaihto	49
	Valotoiminnon käyttäminen	49
	Lapsilukon käyttöönotto	49
	Suodattimen tilan tarkistaminen	50
4	Puhdistus ja huolto	50
	Ilmanpuhdistimen rungon puhdistaminen	50
	Hiukkastunnistimen puhdistaminen	50
	Suodattimen pinnan puhdistaminen	51
	Suodattimen vaihto	51
	Suodattimen nollaus	51
5	Säilytys	52
6	Vianmääritys	52

1 Ilmanpuhdistimesi









Onnittelut AC2936/AC2939-ilmanpuhdistimen hankinnasta.

Hyödynnä Philipsin tuki ja rekisteröi tuotteesi osoitteessa www.philips.com/welcome.

Tuotteen yleiskuvaus (kuva ①)

- A Ohjauspaneeli
- B Ilmanpoistoaukko
- C Hiukkastunnistin
- D NanoProtect Series 3 -suodatin (FY2180/30)
- E Takakansi

Säätimien yleiskuvaus (kuva ②)

	Suodattimen puhdistushälytys		Virtakytkin
	Suodattimen vaihdon hälytys		Tilavaihtopainike
	Suodattimen tila-/nollauspainike		Valopainike
	Näytön vaihtopainike		Tilan näyttö: automaattinen (A), hellävarainen (), turbo- tai lepotila (), Lepotila ()

2 Alkutoimet

Suodattimen asentaminen

Huomautus: Varmista, että ilmanpuhdistin on irrotettu pistorasiasta ennen suodattimen asennusta.

- 1 Poista laitteen takakansi (kuva ③).
- 2 Irrota suodatin laitteesta (kuva ④).
- 3 Irrota ilmanpuhdistussuodattimesta kaikki pakkausmateriaalit (kuva ⑤).
- 4 Aseta suodatin takaisin laitteeseen (kuva ⑥).
- 5 Kiinnitä takakansi takaisin paikalleen (kuva ⑦).

Wi-Fi-merkkivalo

Wi-Fi-kuvakkeen tila	Wi-Fi-yhteyden tila
Vilkkuu oranssina	Muodostaa yhteyttä älypuhelimeen
Vilkkuu valkoisena	Yhteyttä reitittimeen muodostetaan
Palaa valkoisena	Yhteys reitittimeen muodostettu
Pois	Wi-Fi-toiminto poissa käytöstä

Wi-Fi-yhteys

Huomautus:

- Yritysverkkoja (kuten varmenteita ja verkkoprofileja) ei tueta. Suosittelemme asentamaan Philips-ilmanpuhdistimet IoT-laitteita varten luotuun verkkoon tai WPA2-Personal-suojattuun verkkoon.
- Katso (kuten MAC-osoite) ovat Clean Home+ -sovelluksesta verkkomäärittystiedot hallittuja verkkoja varten.



Yhteyden muodostaminen ensimmäistä kertaa

- 1 Lataa ja asenna Philipsin **Clean Home+** -sovellus **App Storesta** tai **Google Playsta**.
- 2 Muodosta älypuhelimella tai tablet-laitteella yhteys Wi-Fi-verkkoon.
- 3 Käynnistä **Clean Home+** -sovellus ja napsauta kohtaa **Yhdistä uusi laite** tai paina **+**-painiketta näytön yläreunassa. Liitä ilmanpuhdistin verkkoon näytön ohjeiden mukaisesti.



Suomi

Nollaa Wi-Fi-yhteys

- 1 Kosketa painikkeita  ja  3 sekunnin ajan, kunnes kuulet äänimerkin.
↳ Wi-Fi-merkkivalo  vilkkuu oranssina.
- 2 Noudata kohdassa “Yhteyden muodostaminen ensimmäistä kertaa” annettuja ohjeita.

Huomautus:

- Yritysverkkoja tai verkkoselaintodennusta edellyttäviä verkkoja ei tueta.
- Tarkista uusin päivitys tuetulle käyttöjärjestelmälle ja laitteille osoitteesta www.philips.com/cleanhome.

3 Ilmanpuhdistimen käyttäminen

Ilmanlaadun merkkivalo

Noin 30 sekunnin kuluttua hiukkastunnistin valitsee värin, joka kertoo ympäröivän ilman hiukkasmäärän.

Huomautus: Ilmanlaadun merkkivalon väri määräytyy korkeimman tason mukaan PM2.5- ja IAI-lukemien perusteella.

IAI tarkoittaa sisäilman allergeenitasoa.

IAI-taso	Ilmanlaadun merkkivalon väri	Ilmanlaatu
1-3	Sininen	Hyvä
4-6	Sininen-violetti	Kohtalainen
7 - 9	Violetti-punainen	Heikko
10-12	Punainen	Erittäin heikko







PM2.5 tarkoittaa alle 2,5 mikrometrin suuruisia ilman mukana kulkeutuvia hiukkasia (epäpuhtauksia).

PM2.5-taso	Ilmanlaadun merkkivalon väri	Ilmanlaatu
≤ 12	Sininen	Hyvä
13-35	Sininen-violetti	Kohtalainen
36-55	Violetti-punainen	Heikko
> 55	Punainen	Erittäin heikko

Virran kytkeminen ja katkaiseminen









Huomautus:

- Liitä ilmanpuhdistimen virtajohto pistorasiaan.
- Jos ilmanpuhdistin on kytkettynä verkkovirtaan sammuttamisen jälkeen, ilmanpuhdistin ottaa käyttöön edelliset asetukset, kun se käynnistetään seuraavan kerran.

- 1 Käynnistä ilmanpuhdistin koskettamalla -painiketta (kuva ).
- 2 Näytössä näkyy --- lämpenemisen aikana. Ilmanpuhdistimessa näkyy IAI/PM2.5-taso ilmanlaadun mittaamisen jälkeen (kuva ).
- 3 Ilmanpuhdistin toimii automaattisessa tilassa, ja näytössä näkyy teksti IAI (kuva ).
- 4 Sammuta ilmanpuhdistin koskettamalla -painiketta 3 sekunnin ajan (kuva ).

Tila-asetuksen vaihtaminen

Voit valita automaattisen, hellävaraisen, turbo- tai lepotilan -painikkeella.



- 1 **Automaattinen tila** (): Ilmanpuhdistin säätää tuulettimen nopeutta automaattisesti ympäristön ilmanlaadun perusteella (kuva ).
- 2 **Turbo-tila** (): Ilmanpuhdistin toimii suurimmalla nopeudella (kuva ).
- 3 **Hellävarainen tila** (): Ilmanpuhdistin toimii hitaalla nopeudella (kuva ).
- 4 **Lepotila** (): Ilmanpuhdistin toimii hiljaisesti hitaalla nopeudella. Näytön valot sammuvat 3 sekunnin kuluttua (kuva ).

Näyttötilan vaihto

Huomautus:

- Laitteen näytössä on oletusarvoisesti IAI-taso (kuva  ja kuva .

Valotoiminnon käyttäminen











Voit sammuttaa kaikki laitteen valot ja ohjauspaneelin valot manuaalisesti koskettamalla valopainiketta . Voit sytyttää kaikki valot uudelleen koskettamalla mitä tahansa painiketta (kuva  ja kuva .

Valoanturin toiminnot:

- Ohjauspaneeli voi sammua, käynnistyä tai himmentyä automaattisesti huoneen valaistuksen mukaan.
- Ohjauspaneeli on sammunut tai se on himmeä, jos huoneessa on hämärää.

Voit ottaa kaikki valot käyttöön koskettamalla mitä tahansa painiketta. Jos laitteella ei tehdä toimintoja, kaikki valot sammuvat tai himmenevät jälleen huoneen valaistuksen mukaan.

Lapsilukon käyttöönotto

- 1 Ota lapsilukko käyttöön painamalla painikkeita  ja  3 sekunnin ajan (kuva ).
 - ↳  näkyy näytössä, vain painikkeet  ja  syttyvät.
 - ↳ Näyttö palaa normaalitilaan 3 sekunnin kuluttua.
- 2 Poista lapsilukko käytöstä painamalla painikkeita  ja  uudelleen 3 sekunnin ajan (kuva ).
 - ↳  näkyy näytössä 3 sekunnin ajan, jonka jälkeen näyttö palaa normaalitilaan.
 - ↳ Kaikki painikkeet syttyvät.

Suodattimen tilan tarkistaminen

- Tarkista suodattimen käyttöiän tila koskettamalla suodattimen tilan tarkistus-/nollauspainiketta  (kuva 22).

Kuvakkeen väri	Näyttö (%)
Sininen	16–100
Sininen–violetti	9–15
Violetti–punainen	4–8
Punainen	0–3

Huomautus: Laite siirtyy takaisin normaaliin näyttöön, jos mitään toimintoja ei tehdä kolmen sekunnin kuluessa.

4 Puhdistus ja huolto

Huomautus:

- Älä yritä puhdistaa hiukkastunnistinta pölynimurilla.
- Katkaise ilmanpuhdistimesta virta ja irrota virtajohto pistorasiasta ennen kuin aloitat seuraavat toimet.

Ilmanpuhdistimen rungon puhdistaminen

Puhdista ilmanpuhdistimen ulko- ja sisäpuoli sekä ilmanpoistoaukko pehmeällä kuivalla liinalla (kuva 23).



Hiukkastunnistimen puhdistaminen

Puhdista hiukkastunnistin kahden kuukauden välein laitteen moitteettoman toiminnan takaamiseksi.

- 1 Puhdista hiukkastunnistin ilmanotto- ja ilmanpoistoaukot pehmeällä harjalla (kuva 24).
- 2 Puhdista hiukkastunnistin kostealla pumpulipuikolla. Kuivaa kaikki osat huolellisesti kuivalla vanupuikolla (kuva 25).

Suodattimen pinnan puhdistaminen

Puhdista suodattimen pinta pölynimurilla, kun suodattimen puhdistushälytys  tulee näyttöön (kuva [26](#)).



- 1 Poista laitteen takakansi (kuva [3](#)).
- 2 Irrota suodatin laitteesta (kuva [27](#)).
- 3 Puhdista suodattimen pinta pölynimurilla (kuva [28](#)).
- 4 Aseta suodatin takaisin laitteeseen (kuva [6](#)).
- 5 Kiinnitä takakansi takaisin paikalleen (kuva [7](#)).
- 6 Kytke laitteeseen virta koskettamalla -painiketta (kuva [8](#)).
- 7 Nollaa suodattimen puhdistusaika pitämällä suodattimen tilan tarkistus-/nollauspainiketta  painettuna 3 sekunnin ajan (kuva [29](#)).
- 8 Pese kätesi huolellisesti suodattimen puhdistuksen jälkeen (kuva [30](#)).

Suodattimen vaihto

Huomautus:



- Suodatinta ei voi pestä eikä käyttää uudelleen.
- Älä haistele suodatinta. Se on kerännyt epäpuhtauksia ilmasta.

Kun suodatin on vaihdettava, suodattimen vaihdon hälytys  syttyy palamaan punaisena (kuva [31](#)).

- 1 Vaihda suodatin Philips NanoProtect Series 3 -suodattimeen (FY2180/30). Noudata kohdassa Suodattimen asentaminen annettuja ohjeita.
- 2 Kytke laitteeseen virta koskettamalla -painiketta (kuva [8](#)).
- 3 Nollaa suodattimen käyttöaika painamalla painiketta  3 sekunnin ajan (kuva [32](#)).
- 4 Pese kätesi huolellisesti suodattimen vaihdon jälkeen (kuva [30](#)).

Suodattimen nollaus

Suodattimen voi vaihtaa jo ennen kuin suodattimen vaihdon hälytys () tulee näyttöön. Suodattimen käyttöaikalaskuri on nollattava manuaalisesti suodattimen vaihdon jälkeen.

- 1 Katkaise laitteen virta painamalla virtapainiketta  3 sekunnin ajan ja irrota sitten virtajohto pistorasiasta (kuva [8](#)).
- 2 Liitä virtajohto pistorasiaan (kuva [33](#)).
- 3 Nollaa suodattimen käyttöaikalaskuri painamalla painikkeita  ja  3 sekunnin ajan 15 sekunnin kuluessa virran kytkemisestä (kuva [34](#)).

5 Säilytys

- 1 Katkaise ilmanpuhdistimen virta ja irrota laitteen virtajohto pistorasiasta.
- 2 Puhdista ilmanpuhdistin, hiukkastunnistin ja suodattimen pinta (katso kohta Puhdistus ja huolto).
- 3 Anna kaikkien osien kuivua kokonaan ennen säilytystä.
- 4 Kääri suodatin ilmatiiviiseen muovipussiin.
- 5 Säilytä ilmanpuhdistinta ja suodatinta viileässä ja kuivassa paikassa.
- 6 Pese kädet aina huolellisesti käsiteltyäsi suodattimia.

6 Vianmääritys

Tämä osio esittää lyhyesti yleisimmät ongelmat, joita saatat kohdata käyttäessäsi laitetta. Jos ongelma ei ratkea alla olevien ohjeiden avulla, ota yhteyttä maasi kuluttajapalvelukeskukseen.

Ongelma	Mahdollinen ratkaisu
Laite ei toimi oikein.	<ul style="list-style-type: none">• Suodattimen vaihdon hälytys on näkynyt näytössä jatkuvasti, mutta kyseistä suodatinta ei ole vaihdettu. Laite on lukittunut. Vaihda suodatin ja nollaa suodattimen käyttöaikalaskuri pitämällä -painiketta painettuna.
Ilmanpoistoaukon ilmavirta on selvästi heikompi kuin ennen.	<ul style="list-style-type: none">• Suodattimen pinta on likainen. Puhdista suodattimen pinta (katso kohta Puhdistus ja huolto).

Ongelma	Mahdollinen ratkaisu
Ilmanlaatu ei parane, vaikka laite on ollut käynnissä pitkään.	<ul style="list-style-type: none"> • Tarkista, että suodattimen pakkausmateriaali on poistettu. • Suodatin ei ole paikallaan laitteessa. Varmista, että suodatin (FY2180/30) on asennettu oikein. • Hiukkastunnistin on märkä. Huoneen kosteustaso on korkea, ja kosteus tiivistyy laitteen sisään. Varmista, että hiukkastunnistin on puhdas ja kuiva (katso kohta Puhdistus ja huolto). • Huone on suuri tai ulkoilman ilmanlaatu on huono. Kun ilmanpuhdistin on käytössä, pidä ovet ja ikkunat suljettuna, jotta laite puhdistaa ilmaa mahdollisimman tehokkaasti. • Sisäilmaan muodostuu epäpuhtauksia erilaisista lähteistä. Sisäilman laatua heikentävät esimerkiksi tupakointi, ruoanlaitto, suitsukkeet, hajusteet tai alkoholi. • Suodattimen käyttöikä on umpeutunut. Vaihda suodatin uuteen.
Ilmanlaadun merkkivalon väri pysyy aina samana.	<ul style="list-style-type: none"> • Hiukkastunnistin on likainen. Puhdista hiukkastunnistin (katso kohta Puhdistus ja huolto).
Laitteesta tulee epätavallista hajua.	<ul style="list-style-type: none"> • Ensimmäisillä käyttökerroilla laitteesta voi tulla hiukan muovin hajua. Tämä on normaalia. Jos laitteesta tulee suodattimien poistamisen jälkeen palaneen hajua, ota yhteyttä Philips-jälleenmyyjään tai Philipsin valtuuttamaan huoltoliikkeeseen. Suodatin saattaa tuottaa hajua sisäilman kaasujen absorptioon vuoksi, kun sitä on käytetty jonkin aikaa. On suositeltavaa pidentää suodattimen käyttöikää asettamalla suodatin suoraan auringonpaisteeseen, jolloin se uudelleenaktivoituu. Jos haju ei häviä, vaihda suodatin.

Ongelma	Mahdollinen ratkaisu
Laite pitää kovaa ääntä.	<ul style="list-style-type: none"> • Tämä on normaalia laitteen turbo-tilassa. • Jos laitteesta kuuluu kovaa ääntä automaattisessa tilassa, ilmanlaatu saattaa olla tavallista heikompi tai sovelluksessa mukautettu asetus kiihdyttää tuulettimen nopeutta. Voit valita lepotilan tai muuttaa asetuksia sovelluksessa. • Ilmanpoistoaukkoon joutuva vierasesine saattaa myös aiheuttaa epänormaalia ääntä. Sammuta laite heti ja poista vierasesine kääntämällä laite ylösalaisin. • Jos laitteesta kuuluu epänormaalia ääntä, ota yhteys oman maasi kuluttajapalvelukeskukseen.
Laite ilmoittaa, että suodatin on vaihdettava, vaikka se on jo vaihdettu.	<ul style="list-style-type: none"> • Olet ehkä jättänyt suodattimen käyttöaikalaskurin nollaamatta. Käynnistä laite. Paina sen jälkeen nollauspainiketta () 3 sekunnin ajan.
Näytössä näkyy virhekoodi E1.	<ul style="list-style-type: none"> • Laitteen moottorissa on toimintahäiriöitä. Ota yhteys oman maasi kuluttajapalvelukeskukseen.

Ongelma

Mahdollinen ratkaisu

Wi-Fi-yhteyden määrittäminen ei onnistu.

- Jos ilmanpuhdistin on yhdistetty Dual Band -reitittimeen eikä se muodosta yhteyttä 2,4 GHz:n taajuutta käyttävään verkkoon, vaihda reitittimen taajuus toiseksi (2,4 GHz) ja yritä muodostaa pariliitos uudelleen. 5 GHz:n verkkoja ei tueta. Jos puhdistin on yhdistetty kaksikaistaiseen reitittimeen, vaihda reitittimen 2,4 GHz:n verkkoon ja yritä muodostaa pariliitos uudelleen.
- Verkkotodennusta käyttäviä verkkoja ei tueta. Julkisia Wi-Fi-verkkoja, kuten toimisto- tai hotelliverkkoja, ei tueta.
- Tarkista, että puhdistin on Wi-Fi-reitittimen toiminta-alueella. Voit yrittää sijoittaa ilmanpuhdistimen lähemmäs Wi-Fi-reitittintä.
- Tarkista, että Wi-Fi-salasana on oikea. Salasanan kirjainkoko on merkitsevä.
- Yritä asennusta uudelleen kohdan "Wi-Fi-yhteyden nollaus" ohjeiden mukaan.
- Pidä laite etäällä muista sähköisistä laitteista, jotka saattavat aiheuttaa häiriötä.
- Tarkista, onko mobiililaite lentokonetilassa. Varmista, että lentokonetila on poissa käytöstä, kun muodostat yhteyden Wi-Fi-verkkoon.
- Jos Wi-Fi-pariliitos epäonnistuu useita kertoja peräkkäin, poista älypuhelimien matkapuhelindata käytöstä Asetukset-osassa ja aloita pariliitos uudelleen.
- Jos ilmanpuhdistimen näytön Wi-Fi-kuvake on tasaisen valkoinen, mutta et näe puhdistinta sovelluksessa, valitse Connect a New Device (Liitä uusi laite) ja lisää puhdistin paikallisesta luettelosta, joka on Aloita määrittäminen -sivulla.
- Tutustu sovelluksen Ohje-osion kattaviin ja ajantasaisiin vianmäärittämissivuihin.

Contenu

1	Votre purificateur d'air	57
	Présentation du produit (Fig. ①)	57
	Vue des commandes (Fig. ②)	57
2	Mise en route	57
	Installation du filtre	57
	Voyant Wi-Fi	58
	Connexion Wi-Fi	58
3	Utilisation du purificateur d'air	59
	Voyant de qualité de l'air	59
	Mise en marche et arrêt	59
	Changer de mode	60
	Changer le voyant d'affichage	60
	Utilisation de la fonction d'activation/de désactivation de la lumière	60
	Configuration du verrouillage enfant	61
	Consulter l'état du filtre	61
4	Nettoyage et entretien	61
	Nettoyage du boîtier du purificateur d'air	61
	Nettoyage du capteur de particules	62
	Nettoyage de la surface du filtre	62
	Remplacement du filtre	62
	Réinitialisation du filtre	63
5	Stockage	63
6	Dépannage	63

1 Votre purificateur d'air









Félicitations pour votre achat d'un purificateur d'air AC2936/AC2939.

Pour profiter pleinement de l'assistance Philips, enregistrez votre produit à l'adresse www.philips.com/welcome.

Présentation du produit (Fig. ①)

- A Panneau de commande
- B Sortie d'air
- C Capteur de particules
- D Filtre NanoProtect série 3 (FY2180/30)
- E Cache arrière

Vue des commandes (Fig. ②)

	Alerte de nettoyage du filtre		Bouton marche/arrêt
	Alerte de remplacement du filtre		Sélecteur de mode
	Bouton de réinitialisation / état du filtre		Bouton d'activation/désactivation de la lumière
	Sélecteur d'affichage		Affichage des modes : Auto (A), Turbo (🌀), Calme (🌀), Veille (🌙)

2 Mise en route

Installation du filtre

Remarque : assurez-vous que le purificateur d'air est débranché de la prise secteur avant d'installer le filtre.

- 1 Tirez sur le cache arrière pour le détacher de l'appareil (Fig. ③).
- 2 Retirez le filtre de l'appareil (Fig. ④).
- 3 Retirez le filtre de purification de l'air de son emballage (Fig. ⑤).
- 4 Placez le filtre dans l'appareil (Fig. ⑥).
- 5 Remettez le cache arrière en place (Fig. ⑦).

Voyant Wi-Fi

État de l'icône Wi-Fi	État de la connexion Wi-Fi
Orange clignotant	Établit une connexion au smartphone
Blanc clignotant	Connexion au routeur
Blanc stable	Connecté au routeur
Éteint	Fonction Wi-Fi désactivée

Connexion Wi-Fi

Remarque :



- Les réseaux d'entreprise (certificats, profils de réseau, etc.) ne sont pas pris en charge. Nous vous recommandons de configurer les purificateurs d'air Philips sur un réseau dédié, créé pour les appareils IoT (Internet des objets), ou des réseaux WPA2-Personal.
- Les détails de la configuration sont fournis dans l'application Clean Home+ (adresse MAC, par exemple) pour vous aider à procéder à la configuration sur des réseaux gérés.

Connexion initiale

- 1 Téléchargez et installez l'application Philips **Clean Home +** depuis l'**App Store** ou **Google Play**.
- 2 Connectez votre smartphone ou votre tablette à votre réseau Wi-Fi.
- 3 Lancez l'application « **Clean Home+** » et cliquez sur « **Connect a New Device** » (Connecter un nouvel appareil) ou appuyez sur le bouton « + » en haut de l'écran. Suivez les instructions à l'écran pour connecter le purificateur d'air à votre réseau.



Réinitialisation de la connexion Wi-Fi

- 1 Appuyez sur  et  pendant 3 secondes, jusqu'à ce que vous entendiez un bip.
↳ Le voyant Wi-Fi  clignote en orange.
- 2 Suivez les étapes 3 dans la section **Connexion initiale**.

Remarque :

- Les réseaux d'authentification de pages Web supplémentaires ou d'entreprise ne sont pas pris en charge.
- visitez www.philips.com/cleanhome pour connaître les dernières mises à jour du système d'exploitation et appareils pris en charge.

3 Utilisation du purificateur d'air

Voyant de qualité de l'air

Au bout de 30 secondes environ, le capteur de particules sélectionne la couleur correspondant à la qualité de l'air ambiant quant aux particules en suspension.

Remarque : la couleur du voyant de qualité de l'air est déterminée par l'indice de risque le plus élevé parmi les mesures des PM2.5 et IAI.

« IAI » correspond au niveau des allergènes de l'air intérieur.

Niveau IAI	Couleur du voyant de qualité de l'air	Niveau de qualité de l'air
1-3	Bleu	Bien
4-6	Bleu-violet	Passable
7-9	Violet-rouge	Mauvaise
10-12	Rouge	Très mauvais



« PM2.5 » correspond aux polluants particuliers d'une taille inférieure à 2,5 micromètres.

Niveau PM2.5	Couleur du voyant de qualité de l'air	Niveau de qualité de l'air
≤12	Bleu	Bien
13-35	Bleu-violet	Passable
36-55	Violet-rouge	Mauvaise
>55	Rouge	Très mauvais

Mise en marche et arrêt

Remarque :





- Branchez la fiche du purificateur d'air sur la prise de courant.
- Si le purificateur d'air reste branché sur la prise électrique après avoir été ÉTEINT, il fonctionnera selon les derniers réglages utilisés lorsqu'il est rallumé.

- 1 Appuyez sur  pour allumer le purificateur d'air (Fig. .
- 2 L'afficheur indique « --- » pendant la montée en puissance. Ensuite, une fois la qualité de l'air mesurée, le purificateur d'air indique les niveaux d'IAI/PM2.5 (Fig. .

- 3 Le purificateur d'air fonctionne en mode Automatique et l'afficheur indique le niveau d'IAI (Fig. ⑩).
- 4 Maintenez le bouton  enfoncé pendant 3 secondes pour éteindre le purificateur d'air (Fig. ⑪).

Changer de mode

Sélectionnez les modes Automatique, Turbo, Calme ou Veille en appuyant sur le bouton .

- 1 **Mode Automatique** (): le purificateur d'air ajuste automatiquement la vitesse du ventilateur en fonction de la qualité de l'air ambiant (Fig. ⑫).
- 2 **Mode Turbo** (): le purificateur d'air fonctionne à vitesse maximale (Fig. ⑬).
- 3 **Mode Calme** (): le purificateur d'air fonctionne à vitesse réduite (Fig. ⑭).
- 4 **Mode Veille** (): le purificateur d'air fonctionne silencieusement à vitesse réduite. Au bout de 3 secondes, l'intensité lumineuse de l'afficheur baisse (Fig. ⑮).

Changer le voyant d'affichage

Remarque :

- L'appareil affiche le niveau d'IAI par défaut (Fig. ⑯ et Fig. ⑰).

Utilisation de la fonction d'activation/de désactivation de la lumière









Vous pouvez appuyer sur le bouton d'activation/désactivation de la lumière  pour éteindre manuellement tous les voyants ainsi que le panneau de commande. Appuyez sur n'importe quel bouton pour allumer tous les voyants (Fig. ⑱ et Fig. ⑲).

Grâce au détecteur de luminosité :

- le panneau de commande s'allume, s'éteint et réduit sa luminosité automatiquement, en fonction de l'éclairage de la pièce.
- Le panneau de commande s'éteint ou réduit sa luminosité lorsqu'il fait sombre.

Appuyez sur n'importe quel bouton pour rallumer les voyants. Si aucune autre action n'est réalisée, tous les voyants s'éteignent ou réduisent leur luminosité afin de s'adapter à la luminosité de la pièce.

Configuration du verrouillage enfant

- 1 Maintenez les boutons  et  enfoncés pendant 3 secondes pour activer le verrouillage enfant (Fig. 20).
 - ↳  s'affiche à l'écran ; seuls les boutons  et  s'allument.
 - ↳ Au bout de 3 secondes, l'affichage retourne à la normale.
- 2 Maintenez à nouveau les boutons  et  enfoncés pendant 3 secondes pour désactiver le verrouillage enfant (Fig. 21).
 - ↳  s'affiche à l'écran pendant 3 secondes, puis l'affichage retourne à la normale.
 - ↳ Tous les boutons s'allument.

Consulter l'état du filtre

- Appuyez sur le bouton  de réinitialisation / vérification de l'état du filtre pour consulter l'état du filtre (Fig. 22).

Couleur de l'icône	Affichage (%)
Bleu	16-100
Bleu-violet	9-15
Violet-rouge	4-8
Rouge	0-3

Remarque : l'affichage normal de l'appareil se rétablit au bout de 3 secondes sans action.

4 Nettoyage et entretien

Remarque :

- N'essayez pas de nettoyer le capteur de particules avec un aspirateur.
- Éteignez le purificateur d'air et débranchez-le de la prise de courant avant la procédure suivante.

Nettoyage du boîtier du purificateur d'air

Utilisez un chiffon doux et sec pour nettoyer l'intérieur et l'extérieur du purificateur d'air, ainsi que la sortie d'air (Fig. 23).



Nettoyage du capteur de particules

Nettoyez le capteur de particules tous les 2 mois pour un fonctionnement optimal de l'appareil.

- 1 Nettoyez l'entrée et la sortie du capteur de particules de l'air à l'aide d'une brosse douce (Fig. 24).
- 2 Nettoyez le capteur de particules à l'aide d'un coton-tige humidifié. Séchez soigneusement toutes les pièces avec un coton-tige sec (Fig. 25).

Nettoyage de la surface du filtre

Nettoyez la surface du filtre à l'aspirateur lorsque l'alerte de nettoyage du filtre  apparaît sur l'afficheur (Fig. 26).



- 1 Tirez sur le cache arrière pour le détacher de l'appareil (Fig. 3).
- 2 Retirez le filtre de l'appareil (Fig. 27).
- 3 Nettoyez la surface du filtre à l'aspirateur (Fig. 28).
- 4 Placez le filtre dans l'appareil (Fig. 6).
- 5 Remettez le cache arrière en place (Fig. 7).
- 6 Appuyez sur le bouton  pour allumer l'appareil (Fig. 8).
- 7 Appuyez sur le bouton de réinitialisation / vérification de l'état du filtre  pendant 3 secondes pour réinitialiser l'intervalle de nettoyage du filtre (Fig. 29).
- 8 Lavez-vous soigneusement les mains après avoir changé le filtre (Fig. 30).

Remplacement du filtre

Remarque :







- Le filtre n'est pas lavable, ni réutilisable.
- Ne sentez pas le filtre car il contient des polluants de l'air.

Lorsque le filtre doit être remplacé, une alerte de remplacement du filtre  s'allume en rouge (Fig. 31).

- 1 Remplacez le filtre en place par un filtre Philips NanoProtect série 3 (FY2180/30). Suivez la procédure du chapitre « Installation du filtre ».
- 2 Appuyez sur le bouton  pour allumer l'appareil (Fig. 8).
- 3 Maintenez enfoncé le bouton  pendant 3 secondes pour réinitialiser l'intervalle de remplacement du filtre (Fig. 32).
- 4 Lavez-vous soigneusement les mains après avoir changé le filtre (Fig. 30).

Réinitialisation du filtre

Vous pouvez également remplacer le filtre avant que l'alerte de remplacement () n'apparaisse sur l'afficheur. Après avoir remplacé un filtre, vous devez réinitialiser manuellement le compteur de durée de vie du filtre.

- 1 Appuyez sur le bouton marche/arrêt  pendant 3 secondes pour éteindre l'appareil et débranchez-le de la prise secteur (Fig. ).
- 2 Branchez le cordon d'alimentation sur la prise secteur (Fig. ).
- 3 Dans les 15 secondes qui suivent la mise en marche, appuyez sur les boutons  et  pendant 3 secondes pour réinitialiser le compteur de durée de vie du filtre (Fig. ).

5 Stockage

- 1 Éteignez le purificateur d'air et débranchez-le de la prise de courant.
- 2 Nettoyez le purificateur d'air, le capteur de particules et la surface du filtre (reportez-vous au chapitre « Nettoyage et entretien »).
- 3 Laissez toutes les pièces sécher entièrement à l'air libre avant de les ranger.
- 4 Enfermez le filtre dans des sacs en plastique étanches.
- 5 Rangez le purificateur d'air et le filtre dans un endroit frais et sec.
- 6 Lavez-vous toujours soigneusement les mains après avoir manipulé les filtres.

6 Dépannage

Cette rubrique présente les problèmes les plus courants que vous pouvez rencontrer avec votre appareil. Si vous ne parvenez pas à résoudre le problème à l'aide des informations ci-dessous, contactez le Service Consommateurs de votre pays.

Problème	Solution possible
L'appareil ne fonctionne pas correctement.	<ul style="list-style-type: none"> • L'alerte de remplacement du filtre est allumée en continu, mais vous n'avez pas remplacé le filtre correspondant. Par conséquent, l'appareil est à présent verrouillé. Dans ce cas, remplacez le filtre et effectuez une pression longue sur le bouton  pour réinitialiser le compteur de durée de vie du filtre.
Le flux d'air qui s'échappe de la sortie d'air est significativement plus faible qu'avant.	<ul style="list-style-type: none"> • La surface du filtre est sale. Nettoyez la surface du filtre (reportez-vous au chapitre « Nettoyage et entretien »).
La qualité de l'air ne s'améliore pas alors que l'appareil fonctionne depuis longtemps.	<ul style="list-style-type: none"> • Vérifiez que le filtre a été retiré de son emballage. • Le filtre n'a pas été placé dans l'appareil. Assurez-vous que le filtre (FY2180/30) est correctement installé. • Le capteur de particules est humide. Le taux d'humidité de votre pièce est élevé et de la condensation se forme. Assurez-vous que le capteur de particules air est propre et sec (reportez-vous au chapitre « Nettoyage et entretien »). • La pièce est grande ou la qualité de l'air extérieur est mauvaise. Pour une purification optimale, fermez les portes et les fenêtres lorsque vous faites fonctionner le purificateur d'air. • Il existe des sources de pollution à l'intérieur : cigarette, cuisine, encens, parfum ou alcool, par exemple. • Le filtre est en fin de vie. Remplacez-le par un filtre neuf.
La couleur du voyant de qualité de l'air reste toujours la même.	<ul style="list-style-type: none"> • Le capteur de particules est sale. Nettoyez le capteur de particules (reportez-vous au chapitre « Nettoyage et entretien »).

Problème	Solution possible
L'appareil produit une odeur étrange.	<ul style="list-style-type: none"> • Lors des premières utilisations, l'appareil peut dégager une odeur de plastique. Ce phénomène est normal. Toutefois, si l'appareil dégage une odeur de brûlé même après le retrait des filtres, contactez votre revendeur Philips ou un Centre Service Agréé Philips. Le filtre peut dégager une odeur après avoir été utilisé pendant un moment en raison de l'absorption de gaz intérieurs. Il est recommandé de réactiver le filtre en le positionnant à la lumière directe du soleil pour une utilisation répétée. Si l'odeur persiste, remplacez le filtre.
L'appareil est extrêmement bruyant.	<ul style="list-style-type: none"> • Ce phénomène est normal lorsque l'appareil fonctionne en mode Turbo. • Si l'appareil est trop bruyant en mode Automatique, il est possible que l'appareil fonctionne à vitesse élevée parce que la qualité de l'air a diminué, ou en raison d'un réglage personnalisé dans l'application. Vous pouvez sélectionner le mode Veille ou changer les réglages dans l'application. • Un bruit élevé anormal peut être causé par une chute d'objet dans l'entrée d'air. Éteignez immédiatement l'appareil et retournez-le pour en retirer l'objet étranger. • En cas de bruit anormal, contactez le Service Consommateurs de votre pays.
L'appareil continue d'indiquer que je dois remplacer un filtre alors que je l'ai déjà fait.	<ul style="list-style-type: none"> • Vous n'avez peut-être pas réinitialisé le compteur de durée de vie du filtre. Allumez l'appareil. Appuyez sur le bouton de réinitialisation () pendant 3 secondes.
Le code d'erreur « E1 » apparaît sur l'afficheur.	<ul style="list-style-type: none"> • Le moteur fonctionne mal. Contactez le Service Consommateurs de votre pays.

Problème	Solution possible
La configuration Wi-Fi a échoué.	<ul style="list-style-type: none"> • Si le routeur auquel votre purificateur est connecté est à double bande et qu'il n'est actuellement pas connecté à un réseau 2,4 GHz, basculez sur une autre bande du même routeur (2,4 GHz), puis réessayez d'appairer votre purificateur. Les réseaux 5 GHz ne sont pas pris en charge. Si votre purificateur est connecté à un routeur double bande, basculez sur le réseau 2,4 GHz du routeur, puis réessayez d'appairer votre purificateur. • Les réseaux d'authentification Web ne sont pas pris en charge. Les réseaux Wi-Fi publics tels que ceux proposés dans les bureaux ou les hôtels ne sont pas pris en charge. • Vérifiez si le purificateur est à portée du routeur Wi-Fi. Vous pouvez essayer de rapprocher le purificateur d'air du routeur Wi-Fi. • Vérifiez si le mot de passe Wi-Fi est correct. Le mot de passe est sensible à la casse. • Recommencez la configuration en suivant les instructions de la section « Réinitialiser la connexion Wi-Fi ». • Éloignez l'appareil de tout autre appareil électronique susceptible de causer des interférences. • Vérifiez si l'appareil mobile est en mode avion. Veillez à désactiver le mode avion lorsque vous vous connectez au réseau Wi-Fi. • Si l'appairage Wi-Fi échoue au bout de plusieurs tentatives, désactivez les données cellulaires de votre smartphone dans la section Paramètres, puis procédez de nouveau à l'appairage. • Si l'icône Wi-Fi sur l'écran de votre purificateur s'affiche en blanc fixe mais que le purificateur n'apparaît pas dans votre application, cliquez sur « Connecter un nouvel appareil » et ajoutez le purificateur depuis la liste locale figurant à la page « Commencer la configuration ». • Consultez la section d'aide de l'application pour obtenir de nombreuses astuces de dépannage à jour.

Indice

1	Purificatore d'aria	68
	Panoramica del prodotto (fig ①)	68
	Panoramica dei comandi (fig ②)	68
2	Operazioni preliminari	68
	Installazione del filtro	68
	Indicatore Wi-Fi	69
	Connessione Wi-Fi	69
3	Utilizzo del purificatore d'aria	70
	Spia della qualità dell'aria	70
	Accensione e spegnimento	70
	Modifica dell'impostazione della modalità	71
	Modifica dell'indicatore display	71
	Utilizzo della funzione di accensione/spegnimento spia	71
	Impostazione del blocco bambini	72
	Controllo dello stato del filtro	72
4	Pulizia e manutenzione	72
	Pulizia del corpo del purificatore d'aria	72
	Pulizia del sensore di particelle	73
	Pulizia della superficie del filtro	73
	Sostituzione del filtro	73
	Reimpostazione del filtro	74
5	Conservazione	74
6	Risoluzione dei problemi	74

1 Purificatore d'aria

Congratulazioni per l'acquisto del purificatore d'aria AC2936/AC2939.

Per usufruire di tutti i vantaggi offerti dall'assistenza Philips, effettuare la registrazione del prodotto su www.philips.com/welcome.

Panoramica del prodotto (fig ①)

A Pannello di controllo

B Uscita dell'aria

C Sensore di particelle

D Filtro NanoProtect Serie 3 (FY2180/30)

E Coperchio posteriore

Panoramica dei comandi (fig ②)

	Avviso di pulizia del filtro		Pulsante on/off
	Avviso di sostituzione del filtro		Pulsante di commutazione della modalità
	Pulsante reset/stato del filtro		Pulsante di accensione/ spegnimento spia
	Pulsante di commutazione del display		Display modalità: automatica (A), turbo (tornado), delicata (star), standby (moon)

2 Operazioni preliminari

Installazione del filtro

Nota: prima di installare il filtro, assicurarsi che il purificatore d'aria non sia collegato alla presa elettrica.

- 1 Tirare il coperchio posteriore e rimuoverlo dall'apparecchio (fig ③).
- 2 Estrarre il filtro dall'apparecchio (fig ④).
- 3 Rimuovere tutto il materiale di imballaggio dai filtri di purificazione dell'aria (fig ⑤).
- 4 Reinscrivere il filtro nell'apparecchio (fig ⑥).
- 5 Riposizionare il coperchio posteriore (fig ⑦).

Indicatore Wi-Fi

Stato dell'icona Wi-Fi	Stato della connessione Wi-Fi
Arancione lampeggiante	Connessione allo smartphone
Bianco lampeggiante	Connessione al router
Bianco fisso	Connesso al router
Off	Funzione Wi-Fi disattivata

Connessione Wi-Fi

Nota:



- Le reti aziendali (ad es. certificazioni, profili di rete) non sono supportate. Si consiglia di configurare i purificatori d'aria Philips su una rete dedicata creata per dispositivi IoT o reti WPA2-Personal.
- I dettagli per la configurazione sono inclusi nell'app Clean Home+ (ad es. indirizzo MAC) per agevolare la configurazione sulle reti gestite.

Prima connessione

- 1 Scaricare e installare l'applicazione Philips “**Clean Home+**” dall'**App Store** o **Google Play**.
- 2 Verificare che lo smartphone o il tablet siano collegati alla rete Wi-Fi.
- 3 Avviare l'app “**Clean Home+**” e fare clic su “**Connetti un nuovo dispositivo**” o premere il pulsante “**+**” nella parte superiore della schermata. Seguire le istruzioni su schermo per collegare il purificatore d'aria alla rete.



Ripristinare la connessione Wi-Fi

- 1 Toccare  e  per 3 secondi fino a quando non viene emesso un segnale acustico.
↳ L'indicatore Wi-Fi  lampeggia in arancione.
- 2 Seguire il passaggio 3 nella sezione “**Prima connessione**”.

Nota:

- Le reti con autenticazione della pagina Web aziendale/aggiuntiva non sono supportate.
- Consultare la pagina Web www.philips.com/cleanhome per gli ultimi aggiornamenti dei sistemi operativi e dei dispositivi supportati.

3 Utilizzo del purificatore d'aria

Spia della qualità dell'aria

Dopo circa 30 secondi, il sensore di particelle seleziona il colore che corrisponde alla qualità delle particelle sospese nell'aria circostante.

Nota: il colore della spia della qualità dell'aria è stabilito dall'indice di rischio più alto dei valori di PM2.5 e IAI.

IAI si riferisce livello di allergeni presenti nell'aria degli ambienti interni.

Livello IAI	Colore della spia della qualità dell'aria	Livello della qualità dell'aria
1-3	Blu	Buona
4-6	Blu-viola	Accettabile
7-9	Viola-rosso	Scarsa
10-12	Rosso	Molto scarsa



PM2.5 si riferisce alle particelle inquinanti presenti nell'aria più piccole di 2,5 micrometri.

Livello PM2.5	Colore della spia della qualità dell'aria	Livello della qualità dell'aria
≤12	Blu	Buona
13-35	Blu-viola	Accettabile
36-55	Viola-rosso	Scarsa
>55	Rosso	Molto scarsa

Accensione e spegnimento

Nota:





- Inserire la spina del purificatore d'aria nella presa di alimentazione.
- Se, dopo averlo spento (OFF), il purificatore resta collegato alla presa d'aria, una volta riacceso (ON) riprenderà a funzionare con le impostazioni precedentemente utilizzate.

- 1 Toccare  per accendere il purificatore d'aria (fig ).
- 2 Durante il riscaldamento, sul display viene visualizzato “---”. Quindi il purificatore d'aria mostra il livello IAI/PM2.5 dopo aver misurato la qualità dell'aria (fig .

- 3 Il purificatore d'aria funziona in modalità automatica con il valore IAI visualizzato sullo schermo (fig 10).
- 4 Toccare e tenere premuto il pulsante  per 3 secondi per spegnere il purificatore d'aria (fig 11).

Modifica dell'impostazione della modalità

È possibile scegliere la modalità automatica, turbo, delicata o standby toccando il pulsante .

- 1 **Modalità automatica** (): il purificatore d'aria regola automaticamente la velocità della ventola a seconda della qualità dell'aria (fig 12).
- 2 **Modalità turbo** (): il purificatore d'aria funziona alla massima velocità (fig 13).
- 3 **Modalità delicata** (): il purificatore d'aria funziona a bassa velocità (fig 14).
- 4 **Modalità standby** (): il purificatore d'aria funziona silenziosamente a velocità molto ridotta. Dopo 3 secondi, lo schermo si spegne (fig 15).

Modifica dell'indicatore display

Nota:

- L'apparecchio mostra il livello IAI per impostazione predefinita (fig 16 e fig 17).

Utilizzo della funzione di accensione/spegnimento spia









È possibile toccare manualmente il pulsante di accensione/spegnimento delle luci  per spegnere tutte le luci e il pannello di controllo. È possibile toccare qualsiasi pulsante per riattivare tutte le luci (fig 18 e fig 19).

Con il sensore luminoso:

- Il pannello di controllo può accendersi, spegnersi o attenuarsi automaticamente in base all'illuminazione ambientale.
- Il pannello di controllo si spegne o si attenua quando l'illuminazione ambientale è scura.

È possibile toccare qualsiasi pulsante per riattivare tutte le luci. Se non vengono eseguite ulteriori operazioni, tutte le luci si spengono o si attenuano nuovamente per adattarsi all'illuminazione ambientale.

Impostazione del blocco bambini

- 1 Toccare e tenere premuti i pulsanti  e  per 3 secondi per attivare il blocco bambini (fig. 20).
 - ↳ Sul display viene visualizzato  e si illuminano solo i pulsanti  e .
 - ↳ Dopo 3 secondi, il display torna alla visualizzazione normale.
- 2 Toccare e tenere premuti nuovamente i pulsanti  e  per 3 secondi per disattivare il blocco bambini (fig. 21).
 - ↳ Sul display viene visualizzato  per 3 secondi e viene ripristinata la visualizzazione normale.
 - ↳ Tutti i pulsanti si illuminano.

Controllo dello stato del filtro

- Toccare il pulsante reset/stato del filtro  per controllare lo stato del filtro (fig. 22).

Colore icona	Display (%)
Blu	16-100
Blu-viola	9-15
Viola-rosso	4-8
Rosso	0-3

Nota: l'apparecchio torna alla visualizzazione normale se non vengono eseguite operazioni per 3 secondi.

4 Pulizia e manutenzione

Nota:

- Non pulire il sensore di particelle con un aspirapolvere.
- Spegner il purificatore d'aria e scollegarlo dalla presa di alimentazione prima di completare la procedura che segue.

Pulizia del corpo del purificatore d'aria

Utilizzare un panno morbido e asciutto per pulire l'interno e l'esterno del purificatore d'aria e l'uscita dell'aria (fig. 23).



Pulizia del sensore di particelle

Per garantire il funzionamento ottimale dell'apparecchio, pulire il sensore di particelle ogni due mesi.

- 1 Pulire le prese del sensore di particelle dell'aria con una spazzola morbida (fig 24).
- 2 Pulire il sensore di particelle con un bastoncino cotonato umido. Asciugare con cura tutte le parti con un bastoncino cotonato asciutto (fig 25).

Pulizia della superficie del filtro

Pulire la superficie del filtro con un aspirapolvere quando sullo schermo viene visualizzato l'avviso di pulizia del filtro  (fig 26).



- 1 Tirare il coperchio posteriore e rimuoverlo dall'apparecchio (fig 3).
- 2 Estrarre il filtro dall'apparecchio (fig 27).
- 3 Pulire la superficie del filtro con un aspirapolvere (fig 28).
- 4 Reinsediare il filtro nell'apparecchio (fig 6).
- 5 Riposizionare il coperchio posteriore (fig 7).
- 6 Per accendere l'apparecchio, toccare il pulsante  (fig 8).
- 7 Toccare e tenere premuto il pulsante reset/stato del filtro  per 3 secondi per reimpostare l'intervallo di pulizia del filtro (fig 29).
- 8 Lavare le mani accuratamente dopo aver pulito il filtro (fig 30).

Sostituzione del filtro

Nota:







- Il filtro non è lavabile o riutilizzabile.
- Non annusare il filtro poiché ha raccolto sostanze inquinanti dall'ambiente.

Quando è necessario sostituire il filtro, l'avviso di sostituzione del filtro  si illumina in rosso. (fig 31).

- 1 Sostituire il filtro con il filtro Philips NanoProtect Serie 3 (FY2180/30), seguire la procedura del capitolo "Installazione del filtro".
- 2 Per accendere l'apparecchio, toccare il pulsante  (fig 8).
- 3 Toccare e tenere premuto il pulsante  per 3 secondi per reimpostare l'intervallo di sostituzione del filtro (fig 32).
- 4 Lavare le mani accuratamente dopo aver sostituito il filtro (fig 30).

Reimpostazione del filtro

È possibile sostituire il filtro anche prima che sullo schermo venga visualizzato l'avviso di sostituzione del filtro (). Dopo aver sostituito un filtro, è necessario ripristinare manualmente il contatore della durata del filtro.

- 1 Toccare il pulsante di accensione  per 3 secondi per spegnere l'apparecchio e staccare la spina dalla presa di corrente (fig  8).
- 2 Collegare la spina alla presa di corrente (fig  33).
- 3 Entro 15 secondi dall'accensione, toccare e tenere premuto il pulsante  e  per 3 secondi per ripristinare il contatore della durata del filtro (fig  34).

5 Conservazione

- 1 Spegnere il purificatore d'aria e scollegarlo dalla presa di alimentazione.
- 2 Pulire il purificatore d'aria, il sensore di particelle e la superficie del filtro (vedere il capitolo “Pulizia e manutenzione”).
- 3 Lasciare asciugare tutte le parti accuratamente prima di riporle.
- 4 Avvolgere il filtro in buste di plastica ermetiche.
- 5 Riporre il purificatore d'aria e il filtro in un luogo fresco e asciutto.
- 6 Lavare sempre accuratamente le mani dopo aver toccato i filtri.

6 Risoluzione dei problemi

In questo capitolo vengono riportati i problemi più comuni legati all'uso dell'apparecchio. Se non è possibile risolvere il problema con le informazioni fornite di seguito, contattare il centro assistenza clienti del proprio paese.

Problema	Possibile soluzione
L'apparecchio non funziona correttamente.	<ul style="list-style-type: none">• L'avviso di sostituzione del filtro si è attivato in modo permanente, ma il relativo filtro non è stato sostituito. Perciò ora l'apparecchio è bloccato. In tal caso, sostituire il filtro e premere  a lungo per reimpostare il contatore della durata del filtro.

Problema	Possibile soluzione
Il flusso d'aria che fuoriesce dalla presa è molto più debole di prima.	<ul style="list-style-type: none"> • La superficie del filtro è sporca. Pulire la superficie del filtro (vedere il capitolo “Pulizia e manutenzione”).
La qualità dell'aria non migliora, sebbene l'apparecchio sia in funzione da parecchio tempo.	<ul style="list-style-type: none"> • Controllare che il materiale di imballaggio sia stato rimosso dal filtro. • Il filtro non è stato inserito nell'apparecchio. Assicurarsi che il filtro (FY2180/30) sia installato correttamente. • Il sensore di particelle è bagnato. L'umidità della stanza è elevata e provoca condensa. Assicurarsi che il sensore di particelle sia pulito e asciutto (vedere il capitolo “Pulizia e manutenzione”). • Le dimensioni della stanza sono grandi o la qualità dell'aria esterna è scarsa. Per prestazioni di purificazione ottimali, chiudere le porte e le finestre quando è in funzione il purificatore d'aria. • Sono presenti sostanze inquinanti all'interno. Ad esempio, fumo, cucina, incenso, profumo o alcol. • Il filtro ha raggiunto la fine del ciclo di vita. Sostituirlo con uno nuovo.
Il colore della spia della qualità dell'aria rimane sempre uguale.	<ul style="list-style-type: none"> • Il sensore di particelle è sporco. Pulire il sensore di particelle (vedere il capitolo “Pulizia e manutenzione”).
Dall'apparecchio fuoriesce uno strano odore.	<ul style="list-style-type: none"> • L'apparecchio può emanare odore di plastica durante i primi utilizzi. Non si tratta comunque di un malfunzionamento dell'apparecchio. Tuttavia, se l'apparecchio emana odore di bruciato anche dopo aver rimosso i filtri, contattare il rivenditore Philips o un centro assistenza Philips autorizzato. Il filtro potrebbe emanare odore in seguito all'utilizzo prolungato a causa dell'assorbimento di gas nell'ambiente interno. È consigliabile riattivare il filtro ponendolo sotto la luce diretta del sole per ulteriori utilizzi. Se il cattivo odore persiste, sostituire il filtro.

Problema	Possibile soluzione
L'apparecchio è molto rumoroso.	<ul style="list-style-type: none"> • È normale se l'apparecchio funziona in modalità turbo. • In modalità automatica, se l'apparecchio è troppo rumoroso, è possibile che funzioni ad alta velocità perché la qualità dell'aria è peggiorata oppure l'impostazione personalizzata nell'app attiva una maggiore velocità della ventola. È possibile scegliere la modalità standby o modificare le impostazioni nell'app. • Un suono anomalo potrebbe essere causato anche da eventuali oggetti introdotti nell'uscita dell'aria. Spegnere immediatamente l'apparecchio e capovolgerlo per far uscire gli oggetti estranei. • Se viene emesso un suono anomalo, contattare il centro assistenza clienti del proprio paese.
L'apparecchio indica ancora che deve essere sostituito un filtro, mentre è già stato sostituito.	<ul style="list-style-type: none"> • Il contatore della durata del filtro potrebbe non essere stato reimpostato. Accendere l'apparecchio. Quindi toccare e tenere premuto il pulsante reset () per 3 secondi.
Sul display viene visualizzato il codice di errore "E1".	<ul style="list-style-type: none"> • Il motore non funziona correttamente. Rivolgersi al centro assistenza clienti del proprio paese.

Problema**Possibile soluzione**

Configurazione
Wi-Fi non riuscita.

- Se il purificatore è connesso a un router dual band e non è attualmente connesso a una rete a 2,4 GHz, passare a un'altra banda dello stesso router (2,4 GHz) e provare nuovamente ad associare il purificatore. Le reti a 5 GHz non sono supportate. Se il purificatore è connesso a un router dual band, passare alla rete a 2,4 GHz del router e provare nuovamente ad associare il purificatore.
- Le reti con autenticazione Web non sono supportate. Wi-Fi pubblici, come le reti di uffici o hotel, non sono supportati.
- Verificare che il purificatore si trovi all'interno della portata del router Wi-Fi. È possibile provare ad avvicinare il purificatore d'aria al router Wi-Fi.
- Verificare che la password Wi-Fi sia corretta. La password fa distinzione tra maiuscole e minuscole.
- Riprovare a eseguire la configurazione seguendo le istruzioni nella sezione relativa al Ripristino della connessione Wi-Fi.
- Tenere l'apparecchio lontano da altri dispositivi elettronici che possono causare interferenze.
- Verificare che il dispositivo mobile non si trovi in modalità aereo. Assicurarsi che la modalità aereo sia disattivata durante la connessione alla rete Wi-Fi.
- Se l'associazione al Wi-Fi non viene effettuata dopo diversi tentativi, attivare i dati cellulare sullo smartphone nella sezione Impostazioni e avviare nuovamente l'associazione.
- Se l'icona Wi-Fi sul display del purificatore è bianca fissa ma il purificatore non è visibile nell'app, fare clic su "Connetti un nuovo dispositivo" e aggiungere il purificatore dall'elenco locale sulla pagina relativa all'avvio della configurazione.
- Consultare la sezione di supporto nell'app per suggerimenti approfonditi e aggiornati in merito alla risoluzione dei problemi.

Inhoud

1	Uw luchtzuiveraar	79
	Productoverzicht (afb. ①)	79
	Overzicht bedieningspaneel (afb. ②)	79
2	Aan de slag	79
	Het filter plaatsen	79
	Wi-Fi-indicator	80
	Wi-Fi-verbinding	80
3	De luchtzuiveraar gebruiken	81
	Luchtkwaliteitsindicator	81
	In- en uitschakelen	81
	De modusinstelling wijzigen	82
	Van displayindicator wisselen	82
	De aan-uitfunctie voor licht gebruiken	82
	Het kinderslot instellen	82
	De filterstatus controleren	83
4	Schoonmaken en onderhoud	83
	De behuizing van de luchtzuiveraar schoonmaken	83
	De deeltjessensor schoonmaken	83
	Het oppervlak van het filter schoonmaken	83
	Het filter vervangen	84
	Filter resetten	84
5	Opbergen	84
6	Problemen oplossen	85

1 Uw luchtzuiveraar









Gefeliciteerd met uw aankoop van luchtzuiveraar AC2936/AC2939.

Wilt u volledig profiteren van de ondersteuning die Philips u kan bieden? Registreer dan uw product op www.philips.com/welcome.

Productoverzicht (afb. ①)

- A Configuratiescherm
- B Luchtuitlaat
- C Deeltjessensor
- D NanoProtect serie 3-filter (FY2180/30)
- E Achterplaat

Overzicht bedieningspaneel (afb. ②)

	Waarschuwing voor filterreiniging		Aan/uit-knop
	Waarschuwing voor filtervervangning		Modusselectiekноп
	Filterstatus/resetknop		Aan-uitknop voor licht
	Displayschakelknop		Modusweergave: automatisch (A), turbo (⊙), rustig (⌚), slaap (☾)

2 Aan de slag

Het filter plaatsen

Opmerking: zorg ervoor dat de luchtzuiveraar niet op het stopcontact is aangesloten voordat u het filter plaatst.

- 1 Trek de achterplaat van het apparaat (afb. ③).
- 2 Trek het filter uit het apparaat (afb. ④).
- 3 Verwijder al het verpakkingsmateriaal van het luchtzuiveringsfilter (afb. ⑤).
- 4 Plaats het filter terug in het apparaat (afb. ⑥).
- 5 Maak de achterplaat opnieuw vast (afb. ⑦).

Wi-Fi-indicator

Wi-Fi-pictogramstatus	Wi-Fi-verbindingstatus
Knippert oranje	Maakt verbinding met de smartphone
Knippert wit	Maakt verbinding met de router
Brandt wit	Verbonden met de router
Uit	Wi-Fi-functie uitgeschakeld

Wi-Fi-verbinding

Opmerking:

- Bedrijfsnetwerken (o.a. certificaten en netwerkprofielen) worden niet ondersteund. We raden u aan Philips-luchtzuiveraars in te stellen op een speciaal netwerk dat is opgezet voor IoT-apparaten of op een WPA2-Personal-netwerk.
- Configuratiegegevens (zoals het Mac-adres) zijn beschikbaar in de Clean Home+ -app voor installatie op beheerde netwerken.

Voor de eerste keer verbinding maken

- 1 Download en installeer de Philips 'Clean Home+'-app in de **App Store** of op **Google Play**.
- 2 Verbind uw smartphone of tablet met uw Wi-Fi-netwerk.
- 3 Open de 'Clean Home+'-app en klik op '**Koppelen met nieuw apparaat**' of druk op de '+'-knop boven aan het scherm. Volg de instructies op het scherm om de luchtzuiveraar op uw netwerk aan te sluiten



De Wi-Fi-verbinding opnieuw instellen

- 1 Houd  en  3 seconden ingedrukt tot u een pieptoon hoort.
↳ De Wi-Fi-indicator  knippert oranje.
- 2 Volg de stappen in het gedeelte '**Voor de eerste keer verbinding maken!**'

Opmerking:

- Netwerken met aanvullende webpagina-authenticatie en zakelijke netwerken worden niet ondersteund.
- Ga naar www.philips.com/cleanhome voor de meest actuele informatie over ondersteunde besturingssystemen en apparaten.

3 De luchtzuiveraar gebruiken

Luchtkwaliteitsindicator

Na circa 30 seconden selecteert de deeltjessensor de kleur die overeenkomt met de luchtkwaliteit en luchtdeeltjes van de omgeving.

Opmerking: de kleur van de luchtkwaliteitsindicator wordt bepaald door de hoogste risico-index uit PM2,5- en IAI-metingen.

IAI staat voor de hoeveelheid allergenen in de lucht in huis.

IAI-niveau	Kleur luchtkwaliteitsindicator	Luchtkwaliteitsniveau
1 - 3	Blauw	Goed
4-6	Blauw-paars	Redelijk
7-9	Paars-rood	Slecht
10-12	Rood	Zeer slecht







PM2,5 staat voor de hoeveelheid vervuilende stofdeeltjes in de lucht die kleiner zijn dan 2,5 micrometer.

PM2,5-niveau	Kleur luchtkwaliteitsindicator	Luchtkwaliteitsniveau
≤12	Blauw	Goed
13-35	Blauw-paars	Redelijk
36-55	Paars-rood	Slecht
>55	Rood	Zeer slecht

In- en uitschakelen









Opmerking:

- Steek de stekker van de luchtzuiveraar in het stopcontact.
- Als de luchtzuiveraar op het stopcontact blijft aangesloten nadat deze is uitgeschakeld, onthoudt de luchtzuiveraar de instellingen wanneer deze weer wordt ingeschakeld.

- 1 Druk op  om de luchtzuiveraar in te schakelen (afb. ).
- 2 '---' wordt tijdens het opwarmen weergegeven op het scherm. Vervolgens toont de luchtzuiveraar na het meten van de luchtkwaliteit de hoeveelheid IAI/PM2,5 (afb. ).
- 3 De luchtzuiveraar werkt in de automatische modus en IAI wordt weergegeven op het scherm (afb. ).
- 4 Houd de knop  3 seconden ingedrukt om de luchtzuiveraar uit te schakelen (afb. ).

De modusinstelling wijzigen

U kunt kiezen tussen de automatische modus, de turbomodus, de rustige modus en de slaapmodus door op de knop  te drukken.

- 1 **Automatische modus ()**: de luchtzuiveraar stemt automatisch de ventilatorsnelheid af op de luchtkwaliteit in de omgeving (afb. ).
- 2 **Turbomodus ()**: de luchtzuiveraar werkt op de hoogste snelheid (afb. ).
- 3 **Rustige modus ()**: de luchtzuiveraar werkt op lage snelheid (afb. ).
- 4 **Slaapmodus ()**: de luchtzuiveraar werkt heel stil op lage snelheid. Het scherm wordt na 3 seconden gedimd (afb. ).

Van displayindicator wisselen

Opmerking:

- Het apparaat geeft standaard het IAI-niveau weer (afb.  en afb. .

De aan-uitfunctie voor licht gebruiken











U kunt met de hand de aan-uitknop voor de verlichting  bedienen om alle lampjes en het bedieningspaneel uit te schakelen. Druk op een willekeurige knop om alle lampjes aan te zetten (afb.  en afb. .

Functie van de lichtsensor:

- Het bedieningspaneel kan automatisch worden in- of uitgeschakeld of worden gedimd op basis van het omgevingslicht.
- De verlichting van het bedieningspaneel wordt uitgeschakeld of gedimd als het donker is.

U kunt een willekeurige knop aanraken om alle verlichting in te schakelen. Wanneer u het apparaat daarna niet meer bedient, gaan alle lampjes weer uit of worden ze gedimd op basis van het omgevingslicht.

Het kinderslot instellen

- 1 Houd de knoppen  en  3 seconden ingedrukt om het kinderslot te activeren (afb. ).
 - ↳  wordt alleen op het scherm weergegeven  en de knop  licht op.
 - ↳ Na 3 seconden keert het scherm terug naar de normale weergave.
- 2 Houd de knoppen  en  opnieuw 3 seconden ingedrukt om het kinderslot te deactiveren. (afb. ).
 - ↳  wordt gedurende 3 seconden op het scherm weergegeven en keert dan terug naar de normale weergave.
 - ↳ Alle knoppen lichten op.

De filterstatus controleren

- Druk op de knop voor het controleren/resetten van de filterstatus  om de status van het filter te controleren (afb. 22).

Pictogramkleur	Scherm (%)
Blauw	16-100
Blauw-paars	9-15
Paars-rood	4-8
Rood	0-3

Opmerking: het apparaat geeft na 3 seconden inactiviteit opnieuw het normale scherm weer.

4 Schoonmaken en onderhoud

Opmerking:

- Probeer de deeltjessensor niet schoon te maken met een stofzuiger.
- Schakel de luchtzuiveraar uit en haal de stekker uit het stopcontact voordat u verdergaat.

De behuizing van de luchtzuiveraar schoonmaken

Gebruik een zachte, droge doek voor het schoonmaken van zowel de binnen- als buitenkant van de luchtzuiveraar en de luchtuitlaat (afb. 23).

De deeltjessensor schoonmaken



Maak de deeltjessensor om de 2 maanden schoon om deze optimaal te laten functioneren.

- 1 Maak de inlaat en de uitlaat van de deeltjessensor schoon met een zachte borstel (afb. 24).
- 2 Maak de deeltjessensor schoon met een vochtig wattenstaafje. Droog alle onderdelen grondig af met een droog wattenstaafje (afb. 25).

Het oppervlak van het filter schoonmaken

Reinig het filteroppervlak met een stofzuiger wanneer de waarschuwing voor filterreiniging  op het scherm wordt weergegeven (afb. 26).

- 1 Trek de achterplaat van het apparaat (afb. 3).
- 2 Trek het filter uit het apparaat (afb. 27).
- 3 Maak de buitenkant van het filter schoon met een stofzuiger (afb. 28).

- 4 Plaats het filter terug in het apparaat (afb. ⑥).
- 5 Maak de achterplaat opnieuw vast (afb. ⑦).
- 6 Raak de knop  aan om het apparaat in te schakelen (afb. ⑧).
- 7 Houd de knop voor het controleren/resetten van de filterstatus  3 seconden ingedrukt om de schoonmaaktijd van het filter te resetten (afb. ⑲).
- 8 Was uw handen grondig na het schoonmaken van het filter (afb. ⑳).

Het filter vervangen

Opmerking:

- Het filter mag niet worden afgewassen of hergebruikt.
- Ruik niet aan het filter, aangezien hier verontreinigingen in zijn verzameld.

Als het filter moet worden vervangen, brandt het waarschuwingssignaal voor het vervangen van het filter  rood (afb. ⑳).

- 1 Vervang het filter door een Philips NanoProtect serie 3-filter (FY2180/30). Volg hierbij de stap in het hoofdstuk 'Het filter plaatsen'.
- 2 Raak de knop  aan om het apparaat in te schakelen (afb. ⑧).
- 3 Houd de knop  3 seconden ingedrukt om de vervangingstijd van het filter te resetten (afb. ㉒).
- 4 Was uw handen grondig nadat u het filter hebt vervangen (afb. ㉓).

Filter resetten

U kunt het filter ook vervangen voordat er een waarschuwingssignaal () op het scherm wordt weergegeven. Nadat u het filter hebt vervangen, moet u de levensduurteller van het filter handmatig resetten.

- 1 Houd de aan-uitknop  3 seconden ingedrukt om het apparaat uit te schakelen en haal de stekker uit het stopcontact (afb. ⑧).
- 2 Steek de stekker in het stopcontact (afb. ㉔).
- 3 Houd binnen 15 seconden na het starten de knoppen  en  3 seconden ingedrukt om de levensduurteller van het filter te resetten (afb. ㉕).

5 Opbergen

- 1 Schakel de luchtzuiveraar uit en haal de stekker uit het stopcontact.
- 2 Maak de luchtzuiveraar, de deeltjessensor en de buitenkant van het filter schoon (raadpleeg het hoofdstuk 'Schoonmaken en onderhoud').
- 3 Laat alle onderdelen goed opdrogen voordat u ze opbergt.
- 4 Wikkel het filter in luchtdichte plastic zakken.

- 5 Bewaar de luchtzuiveraar en het filter op een koele, droge plek.
- 6 Was uw handen altijd grondig na hantering van de filters.

6 Problemen oplossen

Dit hoofdstuk behandelt in het kort de problemen die u kunt tegenkomen tijdens het gebruik van uw apparaat. Als u er niet in slaagt het probleem op te lossen met behulp van de onderstaande informatie, neem dan contact op met het Consumer Care Centre in uw land.

Probleem	Mogelijke oplossing
Het apparaat werkt niet goed.	<ul style="list-style-type: none"> • Het waarschuwingssignaal voor het vervangen van het filter brandt continu maar u hebt het betreffende filter niet vervangen. Nu is het apparaat vergrendeld. Vervang in dit geval het filter en houd  ingedrukt om de levensduurteller van het filter te resetten.
De luchtstroom afkomstig uit de luchtuitlaat is aanzienlijk zwakker dan voorheen.	<ul style="list-style-type: none"> • De buitenkant van het filter is vuil. Maak de buitenkant van het filter schoon (zie het hoofdstuk 'Schoonmaken en onderhoud').
De luchtkwaliteit wordt niet beter, ook niet als het apparaat al gedurende een langere tijd is ingeschakeld.	<ul style="list-style-type: none"> • Controleer of het verpakkingsmateriaal van het filter is verwijderd. • Het filter is niet in het apparaat geplaatst. Controleer of het filter (FY2180/30) goed is geplaatst. • De deeltjessensor is nat. De vochtigheidsgraad in de ruimte is hoog en veroorzaakt condens. Zorg dat de deeltjessensor schoon en droog is (zie het hoofdstuk 'Schoonmaken en onderhoud'). • De ruimte is groot of de kwaliteit van de buitenlucht is slecht. Voor een optimale luchtzuivering sluit u deuren en ramen wanneer u de luchtzuiveraar gebruikt. • Er zijn bronnen van verontreiniging binnenshuis. Bijvoorbeeld roken, koken, wierook, parfum en alcohol. • Het filter heeft het einde van de levensduur bereikt. Vervang het filter.
De kleur van de luchtkwaliteit-sindicator blijft ongewijzigd.	<ul style="list-style-type: none"> • De deeltjessensor is vuil. Maak de deeltjessensor schoon (zie het hoofdstuk 'Schoonmaken en onderhoud').

Probleem	Mogelijke oplossing
Het apparaat produceert een rare geur.	<ul style="list-style-type: none"> • De eerste paar keer dat het apparaat wordt gebruikt, komt er mogelijk een geur van plastic vrij. Dit is normaal. Als het apparaat echter een brandgeur produceert, zelfs nadat u de filters hebt verwijderd, neem dan contact op met uw Philips-dealer of een door Philips geautoriseerd servicecentrum. Na enige tijd gebruik kan het filter gaan ruiken door het absorberen van gassen in de lucht. U wordt aangeraden het filter te heractiveren door dit in direct zonlicht te plaatsen voordat u het weer gebruikt. Als de geur niet verdwijnt, vervangt u het filter.
Het apparaat maakt teveel geluid.	<ul style="list-style-type: none"> • Dit is normaal wanneer het apparaat in de turbomodus staat. • Als het apparaat in de automatische modus te veel geluid maakt, werkt het apparaat mogelijk op hoge snelheid vanwege een verslechterde luchtkwaliteit, of doordat er een hogere ventilatorsnelheid wordt ingeschakeld door een persoonlijke instelling in de app. U kunt de slaapmodus kiezen of de instelling in de app wijzigen. • Als er iets in de luchtuitlaat valt kan dit ook een abnormaal, hard geluid geven. Schakel het apparaat onmiddellijk uit en houd het apparaat ondersteboven om de vreemde voorwerpen uit het apparaat te krijgen. • Als het geluid niet normaal klinkt, neemt u contact op met het Consumer Care Centre in uw land.
Het apparaat blijft aangeven dat er een filter moet vervangen, maar dat heb ik al gedaan.	<ul style="list-style-type: none"> • Mogelijk hebt u de levensduurteller van het filter niet gereset. Schakel het apparaat in. Houd vervolgens de resetknop () 3 seconden ingedrukt.
Foutmelding 'E1' wordt weergegeven op het scherm.	<ul style="list-style-type: none"> • De motor werkt niet goed. Neem contact op met het Consumer Care Centre in uw land.

Probleem	Mogelijke oplossing
De Wi-Fi-installatie is mislukt.	<ul style="list-style-type: none"> • Als de router waarop uw luchtzuiveraar is aangesloten een dual band-router is en er momenteel geen verbinding kan worden gemaakt met een 2,4 GHz-netwerk, schakelt u naar een andere band op dezelfde router (2,4 GHz) en probeert u de luchtzuiveraar opnieuw te koppelen. 5 GHz-netwerken worden niet ondersteund. Als uw luchtzuiveraar is aangesloten op een dual band-router, schakelt u over naar het 2,4 GHz-netwerk van de router en probeert u uw luchtzuiveraar opnieuw te koppelen. • Webverificatienetwerken worden niet ondersteund. Openbare Wi-Fi-netwerken zoals kantoor- of hotelnetwerken worden niet ondersteund. • Controleer of de luchtzuiveraar binnen het bereik van de Wi-Fi-router is. U kunt eventueel de luchtzuiveraar dichterbij de Wi-Fi-router zetten. • Controleer of het Wi-Fi-wachtwoord juist is. Het wachtwoord is hoofdlettergevoelig. • Voer de installatie opnieuw uit aan de hand van de instructies in het gedeelte 'De Wi-Fi-verbinding resetten'. • Houd het apparaat uit de buurt van andere elektronische apparaten die storing kunnen veroorzaken. • Controleer of het mobiele apparaat in de vliegtuigmodus staat. Zorg ervoor dat de vliegtuigmodus is uitgeschakeld wanneer verbinding wordt gemaakt met het Wi-Fi-netwerk. • Als de Wi-Fi-koppeling na meerdere pogingen nog steeds niet lukt, schakelt u mobiele gegevens op uw smartphone uit via de instellingen en start u het koppelen opnieuw. • Als het Wi-Fi-pictogram op het scherm van uw luchtzuiveraar constant wit is, maar de luchtzuiveraar niet wordt weergegeven in uw app, klikt u op 'Een nieuw apparaat aansluiten' en voegt u de luchtzuiveraar toe via de lokale lijst op de pagina 'Installatie starten'. • Raadpleeg het gedeelte Help in de app voor uitgebreide en actuele tips voor het oplossen van problemen.

Innhold

1	Luftrensere din	89
	Produktoversikt (fig. ①)	89
	Oversikt over kontrollknapper (fig. ②)	89
2	Komme i gang	89
	Montering av filteret	89
	Wi-Fi-indikator	90
	Wi-Fi-tilkobling	90
3	Bruke luftrenseren	91
	Lampe for luftkvalitet	91
	Slå av og på	91
	Endring av modusinnstillingene	92
	Bytte displayindikatoren	92
	Bruke av/på-funksjonen for lampen	92
	Stille inn barnesikringen	92
	Kontroll av filterstatus	93
4	Rengjøring og vedlikehold	93
	Rengjøring av luftrenserkabinettet	93
	Rengjøring av partikkelsensoren	93
	Rengjør overflaten på filteret	93
	Skifte filteret	94
	Tilbakestilling av filteret	94
5	Lagring	94
6	Feilsøking	95

1 Luftrensere din









Gratulerer med kjøpet av AC2936/AC2939-luftrensere.

Hvis du vil dra full nytte av støtten som Philips tilbyr, kan du registrere produktet ditt på www.philips.com/welcome.

Produktoversikt (fig. ①)

- A Kontrollpanel
- B Åpning for utluft
- C Partikkelsensor
- D NanoProtect-filter, serie 3 (FY2180/30)
- E Bakdeksel

Oversikt over kontrollknapper (fig. ②)

	Varsel om filterrengjøring		Av/på-knapp
	Varsel om filterbytte		Bytte modus-knapp
	Filterstatus- /tilbakestillingsknapp		Av/på-knapp for lys
	Knapp for bytte av visning		Modusvisning: Auto (A), Turbo (T), Varsom (V), Dvale (D)

2 Komme i gang

Montering av filteret

Merk: Kontroller at luftrensere er koblet fra stikkontakten før du monterer filteret.

- 1 Dra ut bakdekslet, og fjern det fra apparatet (fig. ③).
- 2 Fjern filteret fra apparatet (fig. ④).
- 3 Fjern all emballasje fra luftrensefilteret (fig. ⑤).
- 4 Sett filteret tilbake i apparatet (fig. ⑥).
- 5 Sett bakdekslet på igjen (fig. ⑦).

Wi-Fi-indikator

Wi-Fi-ikonstatus	Status for Wi-Fi-tilkoblingen
Blinkende oransje	Kobler til smarttelefonen
Blinkende hvitt	NanoProtect-filter, serie 3 (FY2180/30)
Vedvarende hvitt	Koblet til ruterens
Av	Wi-Fi-funksjon deaktivert

Wi-Fi-tilkobling

Merk:



- Bedriftsnettverk (f.eks. sertifikater, nettverksprofiler) støttes ikke. Vi anbefaler at du installerer luftrensere fra Philips i et eget nettverk som er opprettet for IoT-enheter eller eget WPA2-nettverk.
- Du finner konfigurasjonsinformasjon i Clean Home+-appen (f.eks. Mac-adresse) for hjelp med oppsett på administrerte nettverk.

Førstegangs forbindelse

- 1 Last ned og installer Philips **Clean Home+**-appen fra **App Store** eller **Google Play**.
- 2 Koble smarttelefonen eller nettbrettet til Wi-Fi-nettverket ditt.
- 3 Start **Clean Home+**-appen og klikk på **Connect a New Device** (Koble til en ny enhet), eller trykk på +-knappen øverst på skjermen. Følg instruksjonene på skjermen for å koble luftrenseren til nettverket ditt.



Tilbakestille Wi-Fi-tilkoblingen

- 1 Trykk på  og  hold nede i tre sekunder til du hører en pipelyd.
↳ Wi-Fi-indikatoren  blinker oransje.
- 2 Følg de tre trinnene i delen **Førstegangs forbindelse**.

Merk:

- Bedriftsgodkjenning / ytterligere nettsidenettverk for godkjenning støttes ikke.
- Gå til www.philips.com/cleanhome for å få den nyeste oppdateringen for støttet operativsystem og støttede enheter.

3 Bruke luftrenseren

Lampe for luftkvalitet

Etter ca. 30 sekunder velger partikkelsensoren den fargen som svarer til luftkvaliteten og luftbårne partikler i omgivelsene.

Merk: Fargen på lampen for luftkvalitet bestemmes av det høyeste risikonivået blant PM2.5- og IAI-avlesningene.

IAI referer til allergennivået i inneluften

IAI-nivå	Farger for luftkvalitet	Luftkvalitetsnivå
1-3	Blå	God
4-6	Blålilla	Middels
7-9	Lilla-rød	Dårlig
10-12	Rød	Svært dårlig



PM2.5 referer til luftbårne forurensende stoffer som er mindre enn 2,5 mikrometer.

PM2.5-nivå	Farger for luftkvalitet	Luftkvalitetsnivå
≤12	Blå	God
13-35	Blålilla	Middels
36-55	Lilla-rød	Dårlig
>55	Rød	Svært dårlig

Slå av og på









Merk:

- Sett støpselet på luftrenseren inn i stikkkontakten.
- Hvis luftrenseren forblir koblet til stikkkontakten etter at den er slått av, bruker luftrenseren de samme innstillingene når den slås på igjen.

- 1 Trykk på  for å slå på luftrenseren (fig. 8).
- 2 «---» vises på skjermen under oppvarming. Deretter viser luftrenseren IAI-/PM2.5-nivået etter å ha målt luftkvaliteten (fig. 9).
- 3 Luftrenseren kjører i Automodus, og IAI vises på skjermen (fig. 10).
- 4 Trykk på og hold inne -knappen i tre sekunder for å slå av luftrenseren (fig. 11).

Endring av modusinnstillingene

Du kan trykke på -knappen for å velge mellom Auto-, Turbo- Dvalemodus eller Varsom modus.



- 1 **Automodus** (): Luftrenseren justerer viftehastigheten etter luftkvaliteten automatisk (fig. ).
- 2 **Turbomodus** (): Luftrenseren kjører på høyeste hastighet (fig. ).
- 3 **Varsom modus** (): Luftrenseren kjører på en lav hastighet (fig. ).
- 4 **Dvalemodus** (): Luftrenseren kjører stillegående på en lav hastighet. Skjermyset dempes etter tre sekunder (fig. ).

Bytte displayindikatoren

Merk:

- Apparatet viser IAI-nivået som standard (fig.  og fig. .

Bruke av/på-funksjonen for lampen











Du kan trykke på av/på-knappen  manuelt for å slå av alle lys og kontrollpanelet. Trykk på en hvilken som helst knapp for å aktivere alle lampene (fig.  og fig. .

Med lyssensoren:

- Kontrollpanelet kan slå seg av/på eller dempes automatisk i henhold til omgivelseslyset.
- Kontrollpanelet er avslått eller dimmet når omgivelseslyset er av.

Du kan trykke på en hvilken som helst knapp for å aktivere alle lampene. Hvis du ikke endrer flere innstillinger, slås alle lampene av eller dempes igjen for å samsvare med omgivelseslyset.

Stille inn barnesikringen

- 1 Trykk på og hold inne - og -knappen i tre sekunder for å aktivere barnesikringen (fig. ).
 - ↳  vises på skjermen. Kun - og -knappen lyser.
 - ↳ Skjermen går tilbake til normal visning etter tre sekunder.
- 2 Trykk på og hold inne - og -knappen i tre sekunder på nytt for å deaktivere barnesikringen (fig. ).
 - ↳  vises på skjermen i tre sekunder, så går den tilbake til normal visning.
 - ↳ Alle knappene lyser.

Kontroll av filterstatus

- Trykk på filterstatus-/tilbakestillingsknappen  for å kontrollere statusen for filterets brukstid (fig. 22).

Ikonfarge	Skjerm (%)
Blå	16-100
Blålilla	9-15
Lilla-rød	4-8
Rød	0-3

Merk: Apparatet går tilbake til normal visning etter tre sekunder uten at det gjøres noe.

4 Rengjøring og vedlikehold

Merk:

- Ikke rengjør partikkelsensoren med en støvsuger.
- Slå av luftrenseren og koble støpselet fra stikkkontakten før følgende handling.

Rengjøring av luftrenserkabinettet

Rengjør både innsiden og utsiden av luftrenseren med en myk og tørr klut (fig. 23).

Rengjøring av partikkelsensoren



Rengjør partikkelsensoren annenhver måned for optimal funksjon av apparatet.

- Rengjør inntaket og uttaket for partikkelsensoren med en myk børste (fig. 24).
- Rengjør partikkelsensoren med en fuktig bomullspinne. Tørk alle deler grundig med en tørr bomullspinne (fig. 25).

Rengjør overflaten på filteret

Rengjør overflaten av filteret med støvsugeren når varselet for filterrengjøring  vises på skjermen (fig. 26).

- Dra ut bakdekslet, og fjern det fra apparatet (fig. 3).
- Fjern filteret fra apparatet (fig. 27).
- Rengjør filterets overflate med en støvsuger (fig. 28).
- Sett filteret tilbake i apparatet (fig. 6).



- 5 Sett bakdekslet på igjen (fig. ⑦).
- 6 Trykk på -knappen for å slå på apparatet (fig. ⑧).
- 7 Trykk på og hold inne filterstatus-/tilbakestillingsknappen  i tre sekunder for å tilbakestille rengjøringsplanen for filteret (fig. ②⑨).
- 8 Vask hendene grundig etter at du har rengjort filteret (fig. ③⑩).

Skifte filteret

Merk:



- Filteret kan ikke vaskes eller brukes flere ganger.
- Ikke lukt på filteret, siden det har samlet opp forurensende stoffer fra luften.

Når filteret må byttes ut, lyser varselampen for bytte av filter  rødt (fig. ③①).

- 1 Bytt ut filteret med Philips NanoProtect-filteret i serie 3 (FY2180/30). Følg trinnet i kapitlet Installere filteret.
- 2 Trykk på -knappen for å slå på apparatet (fig. ⑧).
- 3 Trykk på og hold inne -knappen i tre sekunder for å tilbakestille levetidtelleren for filteret (fig. ③②).
- 4 Vask hendene grundig etter at du har byttet ut filteret (fig. ③⑩).

Tilbakestilling av filteret

Du kan bytte ut filteret før varselet om filterbytte () vises på skjermen. Når du har byttet ut et filter, må du tilbakestille levetidtelleren for filteret manuelt.

- 1 Trykk på -knappen i tre sekunder for å slå av apparatet, og trekk ut støpselet fra stikkontakten (fig. ⑧).
- 2 Sett støpselet i stikkontakten (fig. ③③).
- 3 Levetidtelleren for filteret (fig. ③④) tilbakestilles ved å trykke på og holde inne knappene  og  i tre sekunder før det har gått 15 sekunder fra apparatet ble slått på.

5 Lagring

- 1 Slå av luftrenseren og koble støpselet fra stikkontakten.
- 2 Rengjør luftrenseren, partikkelsensoren og overflaten på filteret (se kapitlet Rengjøring og vedlikehold).
- 3 La alle delene lufttørke helt før de settes til oppbevaring.
- 4 Pakk filteret inn i en lufttett plastpose.
- 5 Oppbevar luftrenseren og filteret tørt og kjølig.
- 6 Vask alltid hendene grundig etter at du har håndtert filtre.

6 Feilsøking

Dette kapittelet oppsummerer de vanligste problemene du kan oppleve med apparatet. Hvis du ikke får løst problemet med informasjonen under, kontakter du forbrukerstøtten der du bor.

Problem	Mulig løsning
Apparatet virker ikke som det skal.	<ul style="list-style-type: none"> • Varselet om filterbytte har vært på kontinuerlig, men du har ikke byttet ut det aktuelle filteret. Som et resultat av dette er apparatet nå låst. I slike tilfeller må du bytte filteret og holde nede  for å tilbakestille levetidtelleren for filteret.
Luftstrømmen som kommer ut av luftuttaket, er betydelig svakere enn før.	<ul style="list-style-type: none"> • Filterets overflate er skitten. Rengjør filterets overflate (se avsnittet «Rengjøring og vedlikehold»).
Luftkvaliteten blir ikke bedre, selv om apparatet har vært i bruk over lang tid.	<ul style="list-style-type: none"> • Sjekk at emballasjen er fjernet fra filteret. • Filteret er ikke montert i apparatet. Kontroller at filteret (FY2180/30) er montert ordentlig. • Partikkelsensoren er våt. Luftfuktigheten i rommet er høy og forårsaker kondens. Sørg for at partikkelsensoren er ren og tørr (se avsnittet «Rengjøring og vedlikehold»). • Rommet er stort eller luftkvaliteten utendørs er dårlig. Lukk alle dører og vinduer når luftrensere er i bruk for å få optimal luftrensing. • Det finnes forurensningskilder innendørs. For eksempel røyking, matlaging, røkelse, parfyme og alkohol. • Filterets brukstid går mot slutten. Bytt ut filteret med et nytt.
Fargen på lampen for luftkvalitet forblir den samme.	<ul style="list-style-type: none"> • Partikkelsensoren er skitten. Rengjør partikkelsensoren (se avsnittet «Rengjøring og vedlikehold»).

Problem	Mulig løsning
Apparatet avgir en merkelig lukt.	<ul style="list-style-type: none"> De første gangene du bruker apparatet, kan det avgis plastlukt. Dette er normalt. Hvis apparatet imidlertid avgir en brent lukt selv etter at du har fjernet filterene, må du ta kontakt med Philips-forhandleren eller et godkjent Philips-servicesenter. Filteret kan avgis en vond lukt hvis det ikke har blitt brukt på en stund fordi innendørgasser har blitt absorbert. Det anbefales at du reaktiverer filteret ved å plassere det i direkte sollys for gjentatt bruk. Hvis lukten fortsatt avgis, må du bytte filter.
Apparatet avgir støy.	<ul style="list-style-type: none"> Dette er normalt hvis apparatet kjører i Turbo-modus. Hvis apparatet støyer i Auto-modus, kan det hende at det kjører på høy hastighet fordi luftkvaliteten forverres eller fordi en tilpasset innstilling i appen utløser en høyere viftehastighet. Du kan velge dvalemodus eller endre innstillingene i appen. Fremmedlegemer i luftuttaket kan også føre til et unormalt høyt lydnivå. Slå av apparatet umiddelbart, og snu det opp-ned for å fjerne fremmedlegemer. Hvis du hører en unormal lyd, må du ta kontakt med forbrukerstøtten i landet du bor i.
Apparatet indikerer fortsatt at jeg må bytte ut et filter, selv om jeg allerede har byttet det.	<ul style="list-style-type: none"> Kanskje du ikke tilbakestilte levetidtelleren for filteret. Slå på apparatet. Trykk på og hold inne tilbakestillingsknappen () i tre sekunder.
Feilkoden «E1» vises på skjermen.	<ul style="list-style-type: none"> Motoren har funksjonsfeil. Ta kontakt med forbrukerstøtten i landet der du bor.

Problem	Mulig løsning
Wi-Fi-oppsettet er ikke vellykket.	<ul style="list-style-type: none">• Hvis ruterer som luftrenseren er koblet til, er dualband og per nå ikke tilkoblet et 2,4 GHz-nettverk, må du bytte til et annet bånd på samme ruter (2,4 GHz), og prøve å pare luftrenseren på nytt. 5 GHz-nettverk støttes ikke. Hvis renseren din er koblet til en tobånds ruter, bytter du til 2,4 GHz-nettverket til ruterer og prøver å sammenkoble luftrenseren på nytt.• Nettverk for nettgodkjenning støttes ikke. Offentlig Wi-Fi, for eksempel kontor- og hotellnettverk, støttes ikke.• Kontroller at renseren er innen rekkevidden til Wi-Fi-ruterer. Du kan prøve å plassere luftrenseren nærmere Wi-Fi-ruterer.• Kontroller at Wi-Fi-passordet er riktig. Passordet skiller mellom små og store bokstaver.• Prøv oppsettet på nytt med instruksjonene i delen «Tilbakestill Wi-Fi-tilkobling».• Hold apparatet unna andre elektroniske enheter som kan forårsake forstyrrelser.• Kontroller om mobilenheten er i flymodus. Pass på at flymodusen er deaktivert når du kobler til Wi-Fi-nettverket.• Hvis Wi-Fi-sammenkoblingen mislykkes etter å ha prøvd flere ganger, slår du på mobildata på smarttelefonen i delen Innstillinger og starter sammenkoblingen på nytt.• Hvis Wi-Fi-ikonet på luftrenserens skjerm er kontinuerlig hvit, men du ikke ser luftrenseren i appen, klikker du på «Koble til en ny enhet» og legger til luftrenseren fra den lokale listen på Startoppsett-siden.• Se i hjelp-delen i appen for å få omfattende og oppdaterte tips om feilsøking.

Índice

1	O seu purificador de ar	95
	Descrição do produto (Fig. ①)	95
	Visão geral dos controlos (Fig. ②)	95
2	Introdução	96
	Instalar o filtro	96
	Indicador de Wi-Fi	96
	Ligação Wi-Fi	96
3	Utilizar o purificador de ar	97
	Luz de qualidade do ar	97
	Ligar e desligar	98
	Alterar a definição do modo	98
	Alterar o indicador do visor	98
	Utilizar a função de ligar/desligar a luz	99
	Verificar o estado do filtro	99
4	Limpeza e manutenção	99
	Limpar o corpo do purificador de ar	99
	Limpeza do sensor de partículas	100
	Limpar a superfície do filtro	100
	Substituir o filtro	100
	Reposição do filtro	101
5	Armazenamento	101
6	Resolução de problemas	101

1 O seu purificador de ar









Parabéns pela compra do purificador de ar AC2936/AC2939.

Para tirar o máximo partido da assistência oferecida pela Philips, registe o seu produto em www.philips.com/welcome.

Descrição do produto (Fig. ①)

- A Painel de controlo
- B Saída de ar
- C Sensor de partículas
- D Filtro NanoProtect Série 3 (FY2180/30)
- E Tampa posterior

Visão geral dos controlos (Fig. ②)

	Alerta de limpeza do filtro		Botão ligar/desligar
	Alerta de substituição do filtro		Botão para mudar de modo
	Botão do estado/reposição do filtro		Botão ligar/desligar luzes
	Botão para mudar de visor		Apresentação de modo: Automático (A), Turbo (T), Suave (S), Sono (M)

2 Introdução

Instalar o filtro

Nota: certifique-se de que o purificador de ar está desligado da tomada elétrica antes de instalar o filtro.

- 1 Puxe a tampa posterior e retire-a do aparelho (fig. ③).
- 2 Retire o filtro do aparelho (fig. ④).
- 3 Retire todos os materiais de embalagem do filtro de purificação de ar (fig. ⑤).
- 4 Volte a colocar o filtro no aparelho (fig. ⑥).
- 5 Volte a colocar a tampa posterior (fig. ⑦).

Indicador de Wi-Fi

Estado do ícone de Wi-Fi	Estado da ligação Wi-Fi
Pisca a laranja	A ligar ao smartphone
Pisca a branco	A ligar ao router
Estável em branco	Ligado ao router
Desligado	Funcionalidade de Wi-Fi desativada

Ligação Wi-Fi

Nota:



- As redes corporativas/empresariais (por exemplo, certificados, perfis de rede) não são suportadas. Recomendamos que configure os purificadores de ar Philips numa rede dedicada, criada para dispositivos IdC ou redes WPA2-Pessoal.
- Os detalhes de configuração são fornecidos na aplicação Clean Home+ (por exemplo, endereço Mac) para ajudar a configurar em redes geridas.

Primeira ligação

- 1 Transfira e instale a aplicação Philips "**Clean Home+**" a partir da **App Store** ou **Google Play**.
- 2 Ligue o seu smartphone ou tablet à rede Wi-Fi.
- 3 Abra a aplicação "**Clean Home+**" e clique em "**Ligar um novo dispositivo**" ou prima o botão "+" na parte superior do ecrã. Siga as instruções apresentadas no ecrã para ligar o purificador de ar à rede.



Repor a ligação Wi-Fi

- 1 Toque em  e  durante 3 segundos até ouvir um sinal sonoro.
↳ O indicador de Wi-Fi  pisca a laranja.
- 2 Siga o passo 3 na secção "**Primeira ligação**".

Nota:

- Não são suportadas redes de autenticação de páginas Web empresariais/adicionais.
- consulte www.philips.com/cleanhome para obter a atualização mais recente dos sistemas operativos e dispositivos suportados.

3 Utilizar o purificador de ar

Luz de qualidade do ar

Depois de aproximadamente 30 segundos, o sensor de partículas seleciona a cor que corresponde à qualidade do ar circundante das partículas transportadas pelo ar.

Nota: a cor da luz da qualidade do ar é determinada pelo índice de risco mais elevado entre as leituras de PM2.5 e IAI.

IAI refere-se ao nível de alérgenos do ar interior.

Nível de IAI	Cor da luz de qualidade do ar	Nível de qualidade do ar
1-3	Azul	Bom
4-6	Azul-roxo	Aceitável
7-9	Roxo-vermelho	Mau
10-12	Vermelho	Muito mau



PM2.5 refere-se a poluentes de partículas transportadas pelo ar inferiores a 2,5 micrómetros.

Nível PM2.5	Cor da luz de qualidade do ar	Nível de qualidade do ar
≤12	Azul	Bom
13-35	Azul-roxo	Aceitável
36-55	Roxo-vermelho	Mau
>55	Vermelho	Muito mau

Ligar e desligar

Nota:

- Ligue a ficha do purificador de ar à tomada elétrica.
- Se ficar ligado à tomada elétrica depois de ser desligado, o purificador funcionará com as definições anteriores quando for novamente ligado.

- 1 Toque em  para ligar o purificador de ar (fig. 8).
- 2 O botão "----" é apresentado no ecrã durante o aquecimento. Em seguida, o purificador de ar apresenta o nível de IAI/PM2.5 depois de medir a qualidade do ar (fig. 9).
- 3 O purificador de ar funciona no modo automático com IAI apresentado no ecrã (fig. 10).
- 4 Mantenha premido o botão  durante 3 segundos para desligar o purificador de ar (fig. 11).

Alterar a definição do modo

Pode seleccionar o modo Automático, o modo Turbo, o modo Suave ou o modo Sono, tocando no botão .

- 1 **Modo Automático (A)**: o purificador de ar ajusta automaticamente a velocidade da ventoinha de acordo com a qualidade do ar ambiente (fig. 12).
- 2 **Modo Turbo (T)**: o purificador de ar funciona na velocidade mais elevada (fig. 13).
- 3 **Modo Suave (S)**: o purificador de ar funciona a uma velocidade baixa (fig. 14).
- 4 **Modo Sono (C)**: o purificador de ar funciona silenciosamente a uma velocidade reduzida. Depois de 3 segundos, o ecrã desliga-se (fig. 15).

Alterar o indicador do visor

Nota:

- O aparelho apresenta o nível IAI por predefinição (fig. 16 e fig. 17).

Utilizar a função de ligar/desligar a luz









Pode tocar manualmente no botão ligar/desligar luzes  para desligar todas as luzes e o painel de controlo. Toque em qualquer botão para ativar todas as luzes (fig. 18) e fig. 19).

Com o sensor da luz:

- o painel de controlo pode ligar, desligar ou escurecer automaticamente de acordo com a luz ambiente.
- O painel de controlo estará desligado ou escurecido quando a luz ambiente estiver escura.

Pode tocar em qualquer botão para ativar todas as luzes. Se não tiver de realizar mais nenhuma operação, todas as luzes serão desligadas ou escurecidas novamente de acordo com a luz ambiente.

Configurar o bloqueio de crianças

- Toque e mantenha premido os botões  e  durante 3 segundos para ativar o bloqueio infantil (fig. 20).
 - ↳  é apresentado no ecrã, só ficam acesos o botão  e o .
 - ↳ Após 3 segundos, o ecrã regressa ao visor normal.
- Toque e mantenha premido os botões  e  durante 3 segundos para desativar o bloqueio infantil (fig. 21).
 - ↳  é apresentado no ecrã durante 3 segundos e regressa ao visor normal.
 - ↳ Todos os botões ficam acesos.

Verificar o estado do filtro

- Toque no botão de verificação/reposição do estado do filtro  para verificar o estado da vida útil do filtro (fig. 22).

Cor do ícone	Visor (%)
Azul	16-100
Azul-roxo	9-15
Roxo-vermelho	4-8
Vermelho	0-3

Nota: o aparelho regressa ao visor normal se não forem realizadas operações após 3 segundos.

4 Limpeza e manutenção

Nota:

- não tente limpar o sensor de partículas com um aspirador.
- Primeiro, desligue o purificador de ar e retire a ficha da tomada elétrica.

Limpar o corpo do purificador de ar

Utilize um pano macio e seco para limpar o interior e o exterior do purificador de ar e a saída de ar (fig. 23).



Limpeza do sensor de partículas

Limpe o sensor de partículas a cada dois meses para o funcionamento ideal do aparelho.

- 1 Limpe a entrada e saída do sensor de partículas com uma escova macia (fig. 24).
- 2 Limpe o sensor de partículas com um cotonete húmido. Seque bem todas as peças com um cotonete seco (fig. 25).

Limpar a superfície do filtro

Limpe a superfície do filtro com um aspirador quando o alerta de limpeza do filtro  for apresentado no ecrã (fig. 26).



- 1 Puxe a tampa posterior e retire-a do aparelho (fig. 3).
- 2 Retire o filtro do aparelho (fig. 27).
- 3 Limpe a superfície do filtro com um aspirador (fig. 28).
- 4 Volte a colocar o filtro no aparelho (fig. 6).
- 5 Volte a colocar a tampa posterior (fig. 7).
- 6 Toque no botão  para ligar o aparelho (fig. 8).
- 7 Mantenha premido o botão de verificação/reposição do estado do filtro  durante 3 segundos para repor o tempo de limpeza do filtro (fig. 29).
- 8 Lave bem as mãos após limpar o filtro (fig. 30).

Substituir o filtro

Nota:



- O filtro não é lavável nem reutilizável.
- Não cheire o filtro, uma vez que este recolheu poluentes do ar.

Quando for necessário substituir o filtro, o alerta de substituição do filtro  acende-se a vermelho (fig. 31).

- 1 Substitua o filtro pelo filtro Philips NanoProtect Série 3 (FY2180/30). Siga o passo do capítulo "Instalar o filtro".
- 2 Toque no botão  para ligar o aparelho (fig. 8).
- 3 Mantenha premido o botão de verificação/reposição do estado do filtro  durante 3 segundos para repor o tempo de substituição do filtro (fig. 32).
- 4 Lave bem as mãos após substituir o filtro (fig. 30).

Reposição do filtro

Também pode substituir o filtro antes de o alerta de substituição do filtro () ser apresentado no ecrã. Após substituir um filtro, tem de repor manualmente o contador da vida útil do filtro.

- 1 Toque no botão de alimentação  durante 3 segundos para desligar o aparelho e desligue a ficha da tomada elétrica (fig. 8).
- 2 Ligue a ficha a uma tomada elétrica (fig. 33).
- 3 No período de 15 segundos após ligar, mantenha premido o botão  e  durante 3 segundos para repor o contador da vida útil do filtro (fig. 34).

5 Armazenamento

- 1 Desligue o purificador de ar e retire a ficha da tomada elétrica.
- 2 Limpe o purificador de ar, o sensor de partículas e a superfície do filtro (consulte o capítulo "Limpeza e manutenção").
- 3 Permita que todas as peças sequem ao ar antes de as armazenar.
- 4 Envolve o filtro com sacos de plástico estanques ao ar.
- 5 Guarde o purificador de ar e o filtro num local fresco e seco.
- 6 Lave sempre as mãos com cuidado depois de manusear os filtros.

6 Resolução de problemas

Este capítulo resume os problemas mais comuns que podem surgir no aparelho. Se não for possível resolver o problema com a ajuda das informações abaixo, contacte o Centro de Apoio ao Cliente no seu país.

Problema	Solução possível
O aparelho não funciona adequadamente.	<ul style="list-style-type: none"> • O alerta de substituição do filtro tem estado continuamente ligado, mas o filtro correspondente não foi substituído. Como resultado, o aparelho fica bloqueado. Neste caso, substitua o filtro e prima continuamente  para repor o contador da vida útil do filtro.
O fluxo de ar que sai da saída de ar é substancialmente mais fraco do que antes.	<ul style="list-style-type: none"> • A superfície do filtro está suja. Limpe a superfície do filtro (consulte o capítulo "Limpeza e manutenção").
A qualidade do ar não melhora, embora o aparelho esteja a funcionar há bastante tempo.	<ul style="list-style-type: none"> • Verifique se o material de acondicionamento foi retirado do filtro. • O filtro não foi colocado no aparelho. Certifique-se de que o filtro (FY2180/30) está corretamente instalado. • O sensor de partículas está molhado. O nível de humidade na divisão é elevado e provoca condensação. Certifique-se de que o sensor de partículas está limpo e seco (consulte o capítulo "Limpeza e manutenção"). • O tamanho da divisão é grande ou a qualidade do ar exterior é fraca. Para um desempenho ideal de purificação, feche as portas e as janelas quando utilizar o purificador de ar. • Existem fontes de poluição no interior. Por exemplo: fumar, cozinhar, queimar incenso, utilizar perfume ou álcool. • O filtro atingiu o fim da vida útil. Substitua o filtro por um novo.
A cor da luz da qualidade do ar permanece sempre igual.	<ul style="list-style-type: none"> • O sensor de partículas está sujo. Limpe o sensor de partículas (consulte o capítulo "Limpeza e manutenção").

Problema	Solução possível
O aparelho produz um odor estranho.	<ul style="list-style-type: none">Nas primeiras vezes que utilizar o aparelho, este poderá produzir um odor a plástico. Isto é normal. No entanto, se o aparelho produzir um cheiro de queimado, mesmo depois de remover os filtros, contacte o seu revendedor Philips ou um centro de assistência Philips autorizado. O filtro pode produzir odor depois de ser utilizado durante algum tempo devido à absorção de gases no interior. É recomendável reativar o filtro colocando-o sob luz solar direta para uso repetido. Se ainda existir odor, substitua o filtro.
O aparelho produz demasiado ruído.	<ul style="list-style-type: none">É normal se o aparelho funcionar no modo Turbo.No modo Automático, se o aparelho fizer demasiado ruído, talvez esteja a funcionar a uma velocidade elevada devido à deterioração da qualidade do ar ou devido à sua definição personalizada na aplicação ativar uma velocidade mais elevada da ventoinha. Pode escolher o modo Sono ou alterar as definições na aplicação.Se cair alguma coisa para dentro da saída de ar, também pode provocar ruídos altos anormais. Desligue imediatamente o aparelho e vire-o ao contrário para retirar os objetos estranhos deste.Se ouvir ruídos anormais, contacte o centro de apoio ao cliente no seu país.
O aparelho continua a indicar que tenho de substituir um filtro, mas já o fiz.	<ul style="list-style-type: none">Talvez não tenha efetuado a reposição do contador da vida útil do filtro. Ligue o aparelho. Toque continuamente no botão de reposição () durante 3 segundos.
O código de erro "E1" é apresentado no ecrã.	<ul style="list-style-type: none">O motor tem anomalias. Contacte o centro de apoio ao cliente do seu país.

Problema**Solução possível**

A configuração de Wi-Fi não foi bem-sucedida.

- Se o router ao qual o purificador está ligado for de banda dupla e, atualmente, não estiver a ligar a uma rede de 2,4 GHz, mude para outra banda do mesmo router (2,4 GHz) e tente emparelhar novamente o purificador. As redes de 5 GHz não são suportadas. Se o seu purificador estiver ligado a um router de banda dupla, mude para a rede de 2,4 GHz do router e tente emparelhar novamente o purificador.
 - As redes de autenticação Web não são suportadas. Redes de Wi-Fi público, como redes de escritórios ou de hotéis não são suportadas.
 - Verifique se o purificador está dentro do alcance do router Wi-Fi. Pode tentar posicionar o purificador de ar mais perto do router Wi-Fi.
 - Verifique se a palavra-passe de Wi-Fi está correta. A palavra-passe diferencia maiúsculas de minúsculas.
 - Tente configurar novamente de acordo com as instruções apresentadas na secção “Reset the Wi-Fi connection”.
 - Mantenha o aparelho afastado de outros dispositivos eletrónicos que possam causar interferências.
 - Verifique se o dispositivo móvel está no modo de voo. Certifique-se de que o modo de voo está desativado ao ligar à rede Wi-Fi.
 - Se o emparelhamento Wi-Fi falhar após várias tentativas, ligue os dados móveis do smartphone na secção Definições e inicie novamente o emparelhamento.
 - Se o ícone de Wi-Fi no visor do purificador se apresentar estável em branco, mas o purificador não estiver visível na aplicação, clique em "Ligar um novo dispositivo" e adicione o purificador na lista local na página "Iniciar configuração".
 - Consulte a secção de ajuda na aplicação para obter dicas de resolução de problemas abrangentes e atualizadas.
-

Innehåll

1	Din luftrenare	110
	Produktöversikt (bild ①)	110
	Översikt av reglage (bild ②)	110
2	Komma igång	110
	Installera filtret	110
	Wi-Fi-indikator	111
	Wi-Fi-anslutning	111
3	Använda luftrenaren	112
	Luftkvalitetslampa	112
	Slå på och av	112
	Ändra autolägesinställningen	113
	Växla skärmindikator	113
	Använda funktionen för att slå på/stänga av lampan	113
	Ställa in barnlåset	113
	Kontrollera filtrets status	114
4	Rengöring och underhåll	114
	Rengöra luftrenaren	114
	Rengöra partikelsensorn	114
	Rengöra filtrets yta	114
	Byta filter	115
	Återställa filter	115
5	Förvaring	115
6	Felsökning	116

1 Din luftrenare









Gratis till köpet av luftrenaren AC2936/AC2939.

Dra nytta av Philips support genom att registrera din produkt på www.philips.com/welcome.

Produktöversikt (bild ①)

- A Kontrollpanel
- B Luftutblås
- C Partikelsensor
- D NanoProtect-filter serie 3 (FY2180/30)
- E Bakre skydd

Översikt av reglage (bild ②)

	Larm för filterrengöring		På/av-knapp
	Larm för filterbyte		Lägesväxlarknapp
	Filtrets status-/återställningsknapp		På/av-knapp för lampa
	Visningsväxlarknapp		Lägesvisning: auto, turbo, skonsam, viloläge

2 Komma igång

Installera filtret

Obs! Kontrollera att luftrenaren är frånkopplad från eluttaget innan du installerar filtren.

- 1 Dra i det bakre skyddet och ta bort det från apparaten (bild ③).
- 2 Dra bort filtret ur apparaten (bild ④).
- 3 Ta bort allt förpackningsmaterial runt luftreningsfiltret (bild ⑤).
- 4 Sätt tillbaka filtret i apparaten (bild ⑥).
- 5 Sätt tillbaka det bakre skyddet (bild ⑦).

Wi-Fi-indikator

Wi-Fi-ikonstatus	Wi-Fi-anslutningsstatus
Blinkar orange	Ansluter till smarttelefonen
Blinkar vitt	Ansluter till routern
Lyser vitt	Ansluten till routern
Av	Wi-Fi-funktionen är inaktiverad

Wi-Fi-anslutning

Obs!



- Företagsnätverk (till exempel certifikat, nätverksprofiler) stöds inte. Vi rekommenderar att du konfigurerar Philips-luftrenare på ett särskilt nätverk som skapats för IoT-enheter eller personliga WPA2-nätverk.
- Du hittar konfigurationsinformation i Clean Home+-appen (till exempel Mac-adress) för att hjälpa till att konfigurera på hanterade nätverk.

Första tidsanslutningen

- 1 Ladda ned och installera Philips ”Clean Home+”-appen från **App Store** eller **Google play**.
- 2 Anslut smarttelefonen eller surfplattan till Wi-Fi-nätverket.
- 3 Starta appen **Clean Home+** och klicka på **Anslut en ny enhet** eller tryck på knappen + längst upp på skärmen. Följ instruktionerna på skärmen för att ansluta luftrenaren till nätverket.



Återställ Wi-Fi-anslutningen

- 1 Tryck på  och  i tre sekunder tills du hör ett pip ljud.
↳ Wi-Fi-indikatorn  blinkar orange.
- 2 Följ steg 3 i avsnittet **Ansluta första gången** .

Obs!

- Företags-/ytterligare webbplatsautentiseringsnätverk stöds inte.
- På www.philips.com/cleanhome hittar du den senaste informationen om vilka operativsystem och enheter som kan användas.

3 Använda luftrenaren

Luftkvalitetslampa

Efter cirka 30 sekunder väljer partikelsensorn den färg som motsvarar den omgivande luftkvaliteten för luftburna partiklar.

Obs! Färgen på lampan för luftkvalitet fastställs av den högsta nivån för PM_{2,5} och IAI.

IAI avser nivån på allergener i inomhusluften.

IAI-nivå	Färg på luftkvalitetslampan	Luftkvalitetsnivå
1–3	Blå	Bra
4–6	Blå–lila	Måttlig
7–9	Lila–röd	Dålig
10–12	Röd	Mycket dålig







PM_{2,5} avser luftburna partikelföroreningar som är mindre än 2,5 mikrometer.

Nivå PM _{2,5}	Färg på luftkvalitetslampan	Luftkvalitetsnivå
≤12	Blå	Bra
13–35	Blå–lila	Måttlig
36–55	Lila–röd	Dålig
>55	Röd	Mycket dålig

Slå på och av









Obs!

- Sätt i luftrenarens stickkontakt i eluttaget.
- Om luftrenaren fortsätter att vara ansluten till eluttaget efter avstängning kommer den att fungera enligt de föregående inställningarna när den slås på igen.

- 1 Tryck på  för att slå på luftrenaren (bild ).
- 2  visas på skärmen under uppvärmning. Därefter visar luftrenaren nivåerna för IAI/PM_{2,5} efter att luftkvaliteten har mätts (bild .
- 3 Luftrenaren körs i autoläget och IAI visas på skärmen (bild .
- 4 Håll knappen  nedtryckt i 3 sekunder för att stänga av luftrenaren (bild .

Ändra autolägesinställningen

Du kan välja autoläge, turboläge, skonsamt läge eller viloläge genom att trycka på knappen .



- 1 **Autoläge** (): Luftrenaren justerar automatiskt fläktens hastighet i enlighet med luftkvaliteten (bild ).
- 2 **Turboläge** (): Luftrenaren körs på högsta hastighet (bild ).
- 3 **Skonsamt läge** (): Luftrenaren körs på låg hastighet (bild ).
- 4 **Viloläge** (): Luftrenaren körs tyst på låg hastighet. Efter tre sekunder släcks skärmen (bild ).

Växla skärmindikator

Obs!

- Apparaten visar IAI-nivån som standard (bild  och bild .

Använda funktionen för att slå på/stänga av lampan











Du kan trycka på lampans på/av-knapp  manuellt för att stänga av alla lampor och kontrollpanelen. Tryck på valfri knapp för att tända alla lampor (bild  och bild .

Med ljussensorn:

- Kontrollpanelen kan aktivera, inaktivera eller dimma automatiskt beroende på det omgivande ljuset.
- Kontrollpanelen är inaktiverad eller dimmad i mörkt ljus.

Du kan trycka på valfri knapp för att tända alla lampor. Om ingen ytterligare åtgärd sker släcks eller dimmas alla lampor igen för att matcha det omgivande ljuset.

Ställa in barnlåset

- 1 Håll knapparna  och  intryckta i tre sekunder för att aktivera barnlåset (bild ).
 - ↳  visas på skärmen och endast knapparna  och  tänds.
 - ↳ Efter tre sekunder återgår skärmen till normal visning.
- 2 Håll knapparna  och  intryckta i tre sekunder igen för att inaktivera barnlåset (bild ).
 - ↳  visas på skärmen i 3 sekunder och återgår sedan till normal visning.
 - ↳ Alla knappar tänds.

Kontrollera filtrets status

- Tryck på knappen för att kontrollera/återställa filterstatus  för att kontrollera statusen på filtrets förbrukningstid (bild [22](#)).

Ikonfärg	Display (%)
Blå	16–100
Blå–lila	9–15
Lila–röd	4–8
Röd	0–3

Obs! Apparaten återgår till normal visning om ingen inmatning sker efter tre sekunder.

4 Rengöring och underhåll

Obs!

- Försök inte rengöra partikelsensorn med en dammsugare.
- Stäng av luftrenaren och dra ut sladden från eluttaget innan du utför följande åtgärd.

Rengöra luftrenaren

Använd en mjuk, torr trasa för att rengöra både insidan och utsidan av luftrenaren och luftutloppet (bild [23](#)).

Rengöra partikelsensorn



Rengör partikelsensorn varannan månad för att apparaten ska fungera optimalt.

- 1 Rengör partikelsensorn intag och utlopp med en mjuk borste (bild [24](#)).
- 2 Rengör partikelsensorn med en fuktig bomullspinne. Torka alla delar ordentligt med en torr bomullspinne (bild [25](#)).

Rengöra filtrets yta

Rengör filtrets yta med en dammsugare när larmet för filterrengöring  visas på skärmen (bild [26](#)).

- 1 Dra i det bakre skyddet och ta bort det från apparaten (bild [3](#)).
- 2 Dra bort filtret ur apparaten (bild [27](#)).
- 3 Rengör filtrets yta med en dammsugare (bild [28](#)).
- 4 Sätt tillbaka filtret i apparaten (bild [6](#)).



- 5 Sätt tillbaka det bakre skyddet (bild 7).
- 6 Tryck på knappen  när du vill slå på apparaten (bild 8).
- 7 Håll knappen för att kontrollera/återställa filterstatus  nedtryckt i tre sekunder för att återställa filterrengöringstiden (bild 29).
- 8 Tvätta händerna noga efter rengöring av filtret (bild 30).

Byta filter

Obs!



- Filtret kan inte tvättas eller återanvändas.
- Lukta inte på filtret eftersom det har samlat in föroreningar från luften.

När filtret behöver bytas ut börjar varningen för filterbyte  lysa rött (bild 31).

- 1 Byt ut filtret mot ett Philips NanoProtect-filter serie 3 (FY2180/30). Följ stegen i kapitlet "Installera filtret".
- 2 Tryck på knappen  när du vill slå på apparaten (bild 8).
- 3 Tryck på och håll ned knappen  i 3 sekunder för att återställa räknaren för förbrukningstid (bild 32).
- 4 Tvätta händerna noga efter byte av filtret (bild 30).

Återställa filter

Du kan även byta ut filtret innan varningen för filterbyte () visas på skärmen. När du har bytt ut ett filter behöver du återställa räknaren för förbrukningstiden för filtret manuellt.

- 1 Håll strömknappen  nedtryckt i tre sekunder för att stänga av apparaten och dra ut sladden ur vägguttaget (bild 8).
- 2 Sätt i kontakten i vägguttaget (bild 33).
- 3 Inom 15 sekunder efter påslagning håller du knapparna  och  nedtryckta i tre sekunder för att återställa räknaren för filtrets förbrukningstid (bild 34).

5 Förvaring

- 1 Stäng av luftrenaren och dra ut sladden från eluttaget.
- 2 Rengör luftrenaren, partikelsensorn och filtrets yta (se kapitlet "Rengöring och underhåll").
- 3 Låt alla delar lufttorka ordentligt innan du ställer undan dem.
- 4 Linda filtret i lufttäta plastpåsar.
- 5 Förvara luftrenaren och filtret på en sval och torr plats.
- 6 Tvätta alltid händerna noggrant efter hantering filtren.

6 Felsökning

I det här kapitlet sammanfattas de vanligaste problemen som du kan råka ut för med apparaten. Om du inte kan lösa problemet med informationen nedan kontaktar du den lokala kundtjänsten.

Problem	Möjlig lösning
Apparaten fungerar inte som den ska.	<ul style="list-style-type: none">• Varningen för filterbyte har lyst oavbrutet, men du har inte bytt ut det motsvarande filtret. Det har resulterat i att apparaten nu är låst. Byt ut filtret och tryck länge på  för att återställa räknaren för förbrukningstiden.
Luftflödet som kommer ur utblåset är mycket svagare än förr.	<ul style="list-style-type: none">• Filtrets yta är smutsigt. Rengör filtrets yta (se kapitlet Rengöring och underhåll).
Luftkvaliteten förbättras inte trots att apparaten har körts länge.	<ul style="list-style-type: none">• Kontrollera om förpackningsmaterialet har tagits bort från filtret.• Filtret har inte placerats i apparaten. Se till att filtret (FY2180/30) är korrekt installerat.• Partikelsensorn är fuktig. Fuktighetsnivån i rummet är högre och orsakar kondens. Se till att partikelsensorn är ren och torr (se kapitlet Rengöring och underhåll).• Rummet är stort eller utomhusluftens kvalitet dålig. För optimal reningsprestanda ska du stänga dörrar och fönster när luftrenaren körs.• Det finns föroreningar inomhus. Till exempel från rökning, matlagning, rökelse, parfym och alkohol.• Filtret når slutet av sin förbrukningstid. Byt ut filtret mot ett nytt.
Luftkvalitetslampan har alltid samma färg.	<ul style="list-style-type: none">• Partikelsensorn är smutsig. Rengör partikelsensorn (se kapitlet Rengöring och underhåll).

Problem	Möjlig lösning
Apparaten avger en konstig lukt.	<ul style="list-style-type: none"> Första gångerna du använder apparaten kan det lukta plast. Det är helt normalt. Men om apparaten luktar bränt fast du har tagit bort filtren kontaktar du din Philips-återförsäljare eller ett av Philips auktoriserade serviceombud. Filtret kan ge lukt när det har använts ett tag eftersom det absorberar inomhusgaser. Vi rekommenderar att du återaktiverar filtret genom att lägga det i direkt solljus, så du kan använda det igen. Om filtret fortfarande luktar byter du ut det.
Apparaten är väldigt högljudd.	<ul style="list-style-type: none"> Det är normalt om apparaten körs i turboläget. Om apparaten låter för mycket i autoläget kan det hända att apparaten körs på en hög hastighet eftersom luftkvaliteten försämras eller din anpassade inställning i appen utlöser en högre fläkthastighet. Du kan välja viloläget eller ändra inställningarna i appen. Ett onormalt ljud kan även uppstå om något trillar ned i luftutloppet. Stäng omedelbart av apparaten och vänd apparaten upp och ned för att få ut det främmande föremålet. Kontakta ditt lands kundtjänst om ett onormalt ljud hörs.
Apparaten indikerar fortfarande att jag måste byta ut ett filter trots att jag redan gjort det.	<ul style="list-style-type: none"> Du kanske inte har återställt förbrukningstiden för filter. Slå på apparaten. Tryck och håll ner återställningsknappen (🔄) i tre sekunder.
Felkoden "E1" visas på skärmen.	<ul style="list-style-type: none"> Motorn fungerar inte som den ska. Kontakta kundtjänst i ditt land.

Problem	Möjlig lösning
Wi-Fi-installationen lyckades inte.	<ul style="list-style-type: none"> • Om routern som luftrenaren är ansluten till är dual band och inte går att ansluta till ett 2,4 GHz-nätverk kan du växla till ett annat band på samma router (2,4 GHz) och försöka para ihop med igen. 5 GHz-nätverk kan inte användas. Om luftrenaren är ansluten till en dual band-router växlar du till routerns 2,4 GHz-nätverk och försöker para ihop luftrenaren igen. • Webbautentiseringsnätverk kan inte användas. Offentliga trådlösa nätverk som kontors- eller hotellnätverk stöds inte. • Kontrollera om renaren är inom räckvidd från Wi-Fi-routern. Du kan försöka placera luftrenaren närmare Wi-Fi-routern. • Kontrollera att Wi-Fi-lösenordet stämmer. Lösenordet är skiftlägeskänsligt. • Försök konfigurera igen med instruktionerna i avsnittet Reset Wi-Fi Connection (återställ Wi-Fi-anslutning). • Håll apparaten på avstånd från andra elektroniska enheter som kan orsaka störning. • Kontrollera om den mobila enheten är i flygplansläge. Se till att du har flygplansläget avaktiverat när du ansluter till Wi-Fi-nätverket. • Om Wi-Fi-ihoppningen misslyckas efter flera försök slår du på mobildata på smarttelefonen i avsnittet Settings (inställningar) och påbörjar ihoppningen igen. • Om Wi-Fi-ikonen på skärmen på luftrenaren är vit utan att luftrenaren visas i appen klickar du på Connect a New Device (anslut en ny enhet) och lägger till luftrenaren från den lokala listan på sidan Begin setup (starta konfiguration). • Gå till hjälpaavsnittet i appen om du vill ha omfattande och uppdaterade felsökningstips.



